

User Presentations

Would you like to show off:
Your Company?
Products you design?
How you use Creo?

Email us for information

3riversprug@gmail.com

CAD News:**The Uncovering CAD Trends and Challenges**

<http://creo.ptc.com/2015/09/08/new-survey-uncovering-cad-trends-and-challenges/>

Q&A: The Future of CAD Part 2

<http://www.3dcadworld.com/qa-jon-hirschtick-future-cad-part-ii/>

The Three Rivers Pro/USER Group Board of Directors.

- Eric Holmes, Philips Inc.
- Jaime Clarke, Philips Inc.
- Mike Kline, ALM Machine

Please contact us at:

3riversprug@gmail.com

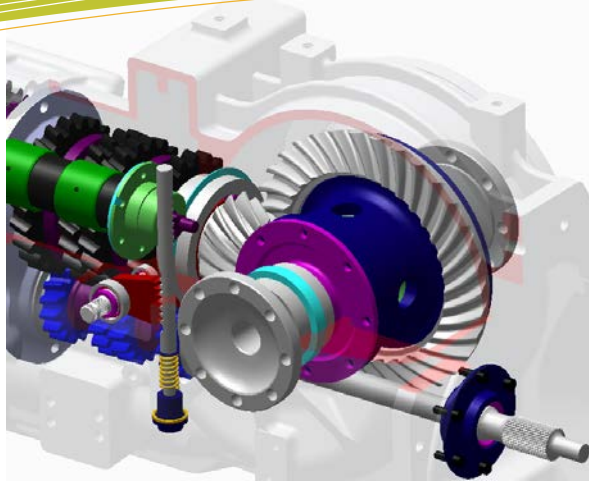
**this issue**

Location, Agenda **P.1**

Registration Information **P.2**

Directions **P.2**

Holiday Inn, Monroeville PA

Located near the intersection of Routes 22 and 48 (behind Max and Erma's)

October 13th, 2015 Agenda

7:15 - 7:45	Coffee & Danish, Networking
7:45 - 8:00	Welcome and Issues: Eric Holmes, Philips / Respirationics
8:00 - 8:45	Creo Tool Design: Boundary Systems
8:45 - 9:30	Using the "Free Stuff" in Creo: EAC Product Development
9:30 - 10:15	Windchill MPMLink: PTC
10:15 - 10:30	Break, Networking, Vendor Booths
10:30 - 11:15	TBD
11:15 - 12:00	Windchill PartsLink: PTC
12:00 - 1:00	Lunch
1:00 - 1:45	Creo Simulate w/ Optimus: Boundary Systems
1:45 - 2:00	Break, Networking, Vendor Booths
2:00 - 2:45	Tips and Tricks (Webex): PTC
2:45 - 3:00	Vendor Raffle

Please visit our Sponsoring Companies @

Boundary Systems: <http://www.boundarysys.com>

EAC Product Development Solutions: <http://www.eacpds.com/>

Rapid Manufacturing: <http://www.rapidmanufacturing.com>

Meeting Registration Form



Company Name: _____

Total Attendees: (x \$40.00) _____

Please send check or money order payable to:

Three Rivers Pro User Group

For \$40.00 per person to the address below no later than

Tuesday October 6th, 2015

Mail to

THREE RIVERS Pro/USERS GROUP

c/o Jaime Clarke

1740 Golden Mile Highway

Monroeville PA, 15146

PLEASE NOTE
NEW ADDRESS



Attendee Names

(please print)

Credit card payment option through PayPal™
We can also process credit card transactions at the door using the
Paypal PayHere service.

Payments are done through a secure mobile connection for an additional 2.7% charge. A \$40 registration fee would be \$41.08. Receipts will be issued.

<https://www.paypal.com/webapps/mpp/credit-card-reader>

ALL NAMES WILL BE
KEPT CONFIDENTIAL

To pay by Credit Card:

Please send an e-mail to: 3riversprorug@gmail.com with your contact information: **Company Name, Telephone number, Attendee names** and we will forward an invoice that will allow you to process your payment via PayPal.

DO NOT forward credit card information. Three Rivers Pro/User Group is not responsible for processing credit payments

Directions to Holiday Inn, Monroeville PA

From PA Turnpike I-76: (North West – South East)

Take the I-76 (PA Turnpike) towards Pittsburgh, Take exit 57 for US-22 W toward Pittsburgh, Follow signs for U.S. 22 Business/Monroeville and merge onto US-22 BUS W, Turn left onto Mosside Blvd, Turn left onto Holiday Lane

From Airport: (Moon)

Rt. 60 to Pittsburgh. Merge onto Rt 22/30 (Rt changes to 279N). Go through tunnel and exit to the right for I-376E (exit 6A). On I-376E, take exit 84A. Merge onto Mosside Blvd and stay straight thru first light. Turn left at next light onto Holiday Lane.

If your location is not listed above please check the facility website or use your GPS.

Holiday Inn Monroeville, 2753-2799 Holiday Lane, Monroeville, PA 15146 Phone: 412-372-1002 | Fax: 412-373-4065

<http://www.holidayinn.com/hotels/us/en/monroeville/mnrpa/hoteldetail>