

# PTC® Live Global

## Retail PLM Solution Update

**Francois Lamy**

Vice-President of Solution Management, PLM Segment

June 2015



## Maintain growth in Retail PLM

## Become a Retail IoT leader

**USABILITY**

**INTEGRATION**

**MATERIAL SUPPLY CHAIN**

**CONSUMER PRODUCTS**



# Where are we today ?

- Windchill FlexPLM 10.2 M030 released
- Largest single release effort for FlexPLM in the last 10 years
- Bringing together Windchill PDMLink and FlexPLM for broader cross product integration
- Leveraging Windchill Upgrade Framework

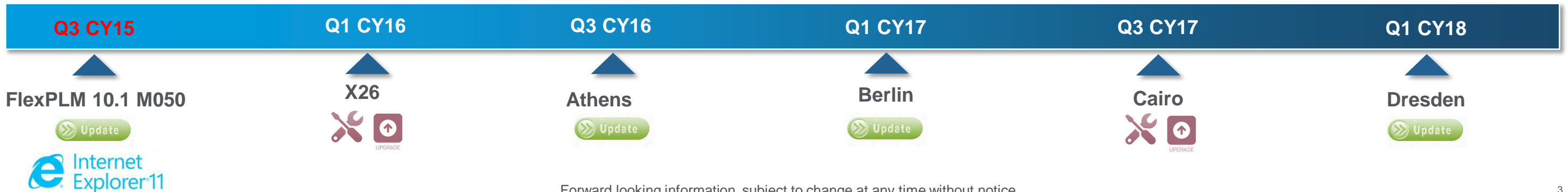

## Enterprise Scalability

- Simplified product configuration
  - Windchill Type Manager extended to support FlexPLM data model and attributes
  - Modern user interface for improved usability :
  - Automatic migration to new data model

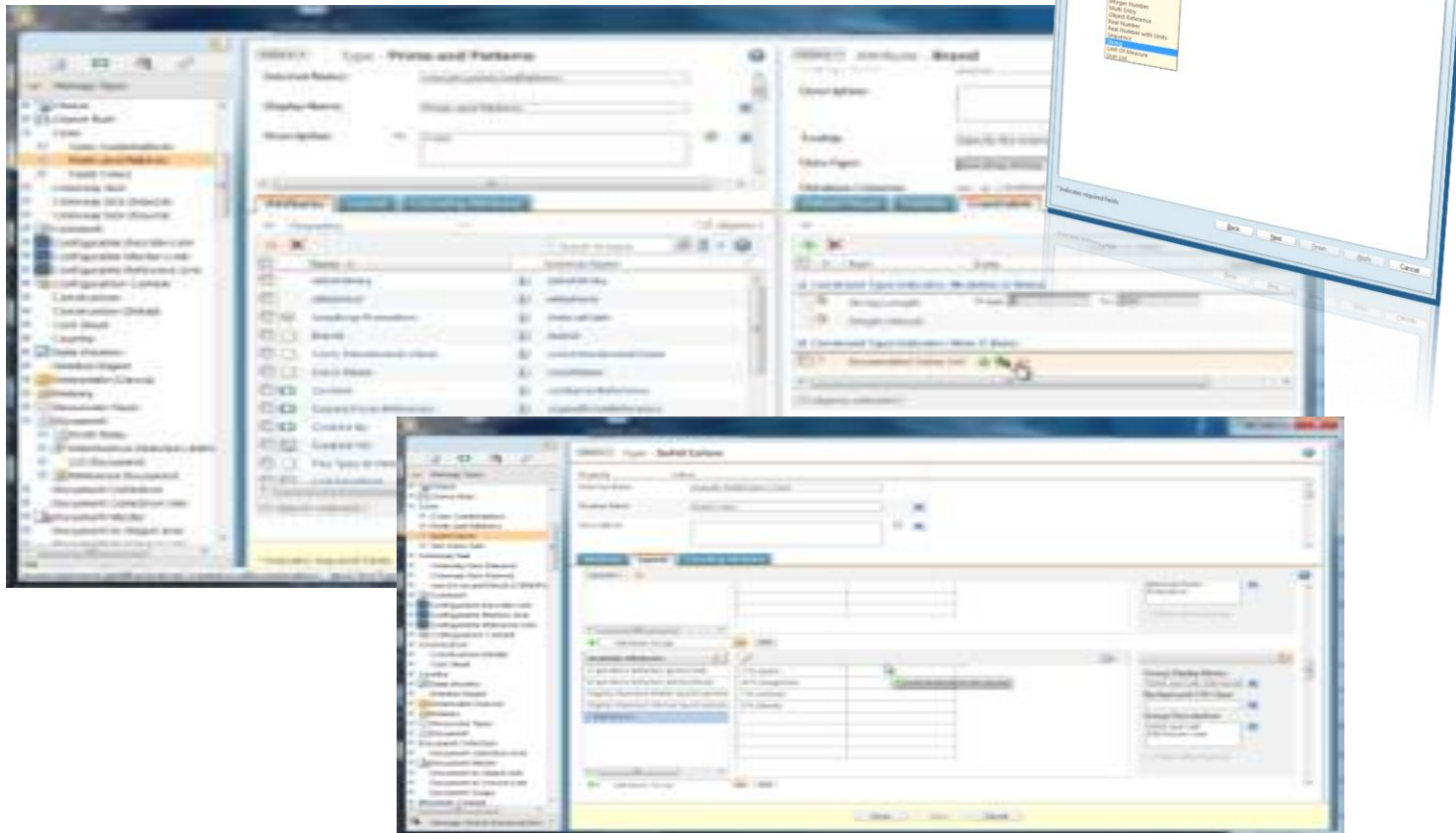

## Flexible Reporting

- Simpler report creation via “query building” GUI
- Support for charting of report results
- Automated report generation and scheduled delivery

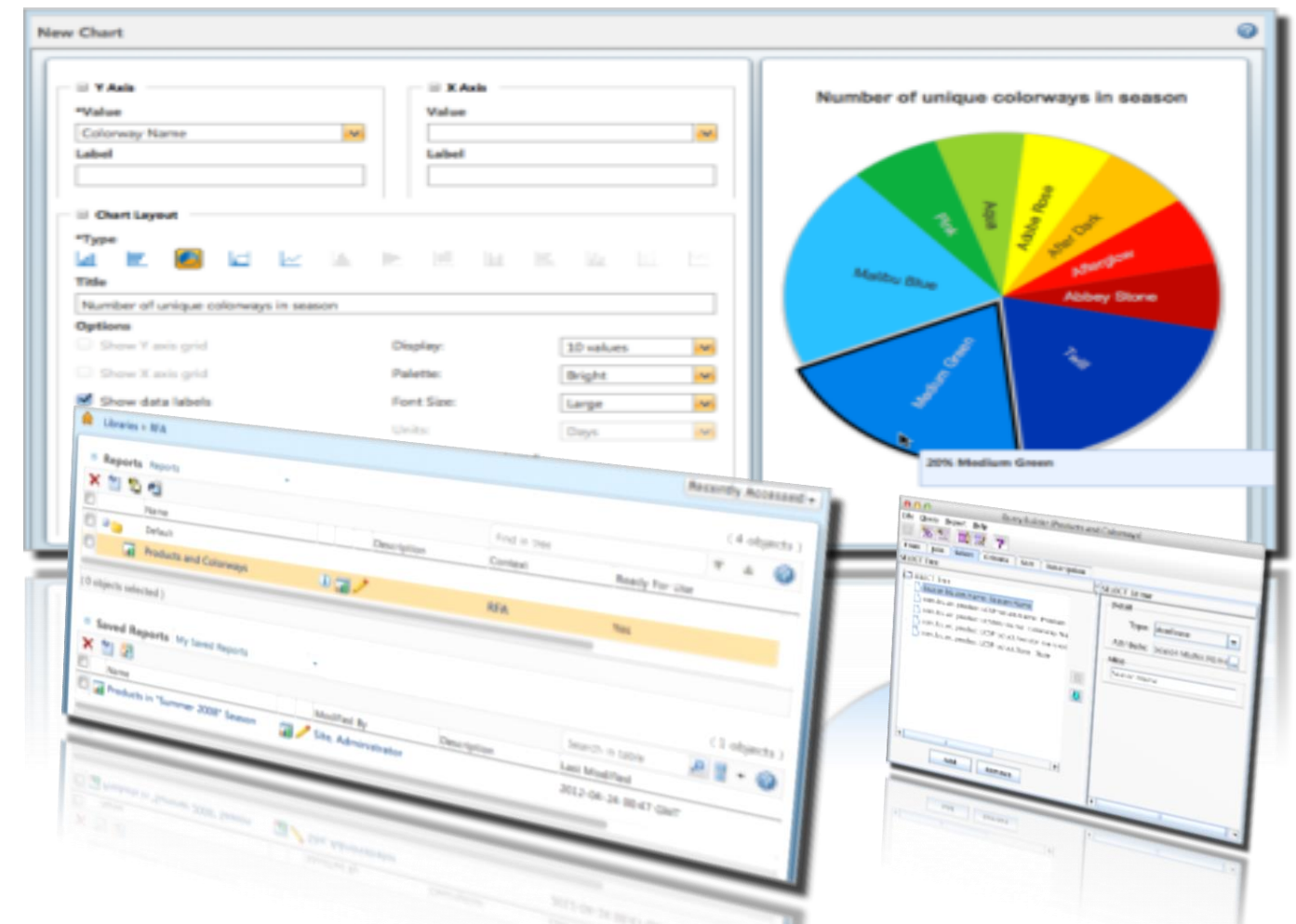

## Customer driven enhancements

- Create material-color sample from palette
- View material-color samples and attributes from palette
- Edit the name of product and colorway level line boards
- Export the line sheet to Excel, including line sheet name
- Remove multiple components from a spec
- Better system navigation after deleting a material-color
- Remove default check for update measurement set
- Better messaging for Update POMs and Re-apply POMs buttons
- Add a material (without a thumbnail) to a design card



## Customer driven enhancements



- Create material-color sample from palette
- View material-color samples and attributes from palette
- Edit the name of product and colorway level line boards
- Export the line sheet to Excel, including line sheet name • Remove multiple components from a spec
- Better system navigation after deleting a material-color
- Remove default check for update measurement set
- Better messaging for Update POMs and Re-apply POMs buttons
- Add a material (without a thumbnail) to a design card

## Key Features

- Enables a view of materials-colors for a particular season as well as the ability to create samples from this “filtered” view.
- Select one or more materials from a season palette and choose the *Create New Color Development Request* action from the drop down

## Value

- Less navigation and increased speed in creating samples due to easy grouping of material-colors and sample action combined on one page

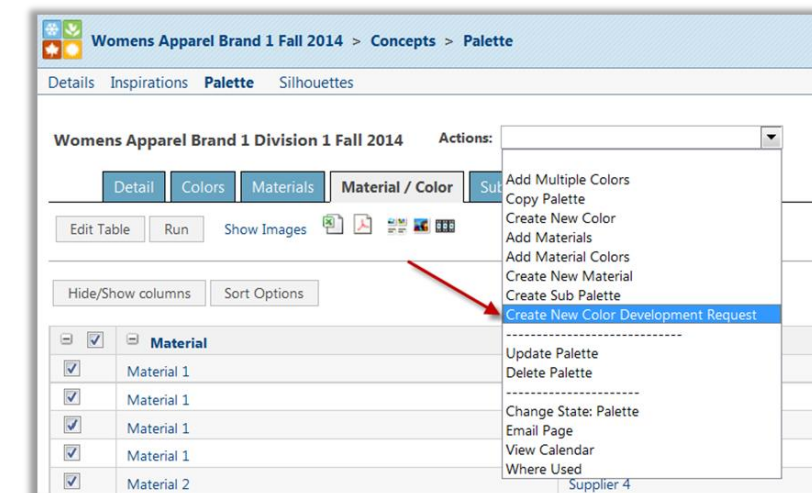

## Customer driven enhancements



- Create material-color sample from palette
- **View material-color samples and attributes from palette**
- Edit the name of product and colorway level line boards
- Export the line sheet to Excel, including line sheet name • Remove multiple components from a spec
- Better system navigation after deleting a material-color
- Remove default check for update measurement set
- Better messaging for Update POMs and Re-apply POMs buttons
- Add a material (without a thumbnail) to a design card

## Key Features

- Ability to view material-colors for a particular season palette and also view related sample data
- Define palette views to include both sample name and sample attributes
- The view will include all samples on the material-colors (it does not filter samples by season)

## Value

- Less time spent in the sample or material libraries trying to filter for material groups that are relevant to a particular season as well as their sample data

|  | Material   | Supplier   | Color    | Request Name | Name       | Quantity |
|--|------------|------------|----------|--------------|------------|----------|
|  | Material 1 | Supplier 2 | Color 13 | Lab Dip      | Sample - 1 | 1        |
|  | Material 1 | Supplier 5 | Color 16 | Lab Dip      | Sample - 1 | 1        |
|  | Material 1 | Supplier 5 | Color 17 | Lab Dip      | Sample - 1 | 1        |
|  | Material 1 | Supplier 4 | Color 19 | Lab Dip      | Sample - 1 | 1        |

## Customer driven enhancements



- Create material-color sample from palette
- View material-color samples and attributes from palette
- **Edit the name of product and colorway level line boards**
- Export the line sheet to Excel, including line sheet name
- Remove multiple components from a spec
- Better system navigation after deleting a material-color
- Remove default check for update measurement set
- Better messaging for Update POMs and Re-apply POMs buttons
- Add a material (without a thumbnail) to a design card

## Key Features

- From a chosen product or colorway line board, use new *Name* field to change the line board name

## Value

- Users are no longer stuck with an inaccurate line board name.
- Users can avoid deleting a line board and starting over as a workaround to providing a more accurate line board name.

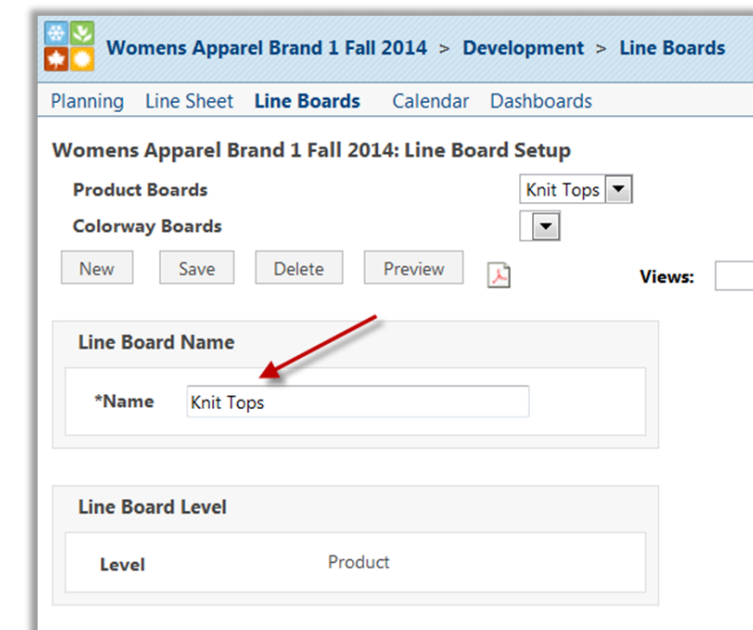



## Customer driven enhancements



- Create material-color sample from palette
- View material-color samples and attributes from palette
- Edit the name of product and colorway level line boards
- **Export the line sheet to Excel, including line sheet name** • **Remove multiple components from a spec**
- Better system navigation after deleting a material-color
- Remove default check for update measurement set
- Better messaging for Update POMs and Re-apply POMs buttons
- Add a material (without a thumbnail) to a design card

## Key Features

- Line sheet Excel export includes the line sheet name in both the worksheet and the tab label

## Value

- Easier to use exports with less manual data entry
- Reduction in errors since the export will include accurate FlexPLM data

The screenshot shows the 'Brand 1 Spring 2015 : Line Sheet Viewer' interface. It features a navigation bar with 'Planning', 'Line Sheet', 'Line Boards', 'Calendar', and 'Dashboards'. Below the navigation bar, there are tabs for 'Brand 1 Spring 2015 : Line Sheet Viewer' and 'Actions:'. The main content area displays 'Results 1-3 of 3 in 0.102 Seconds' and includes buttons for 'Filters', 'Options', and 'Run'. A table is shown with columns A through E and rows 1 through 4. The table content is as follows:

|   | A   | B            | C                      | D | E |
|---|---|--------------|------------------------|---|---|
| 1 | Line Sheet - Womens Apparel Brand 1 Fall 2014 |              |                        |   |   |
| 2 |   | Product Name | Sourcing Configuration |   |   |
| 3 |   | Skirt        | 001 :                  |   |   |
| 4 |   |              |                        |   |   |

## Customer driven enhancements



- Create material-color sample from palette
- View material-color samples and attributes from palette
- Edit the name of product and colorway level line boards
- Export the line sheet to Excel, including line sheet name
- Remove multiple components from a spec
- **Better system navigation after deleting a material-color**
- Remove default check for update measurement set
- Better messaging for Update POMs and Re-apply POMs buttons
- Add a material (without a thumbnail) to a design card

## Key Features

- From the row action of a material-color, deleting a material-color will navigate users back to the material with the color tab selected

## Value

- Users will not longer be stuck at a delete successful dead end and will be able to easily continue to delete additional material-colors

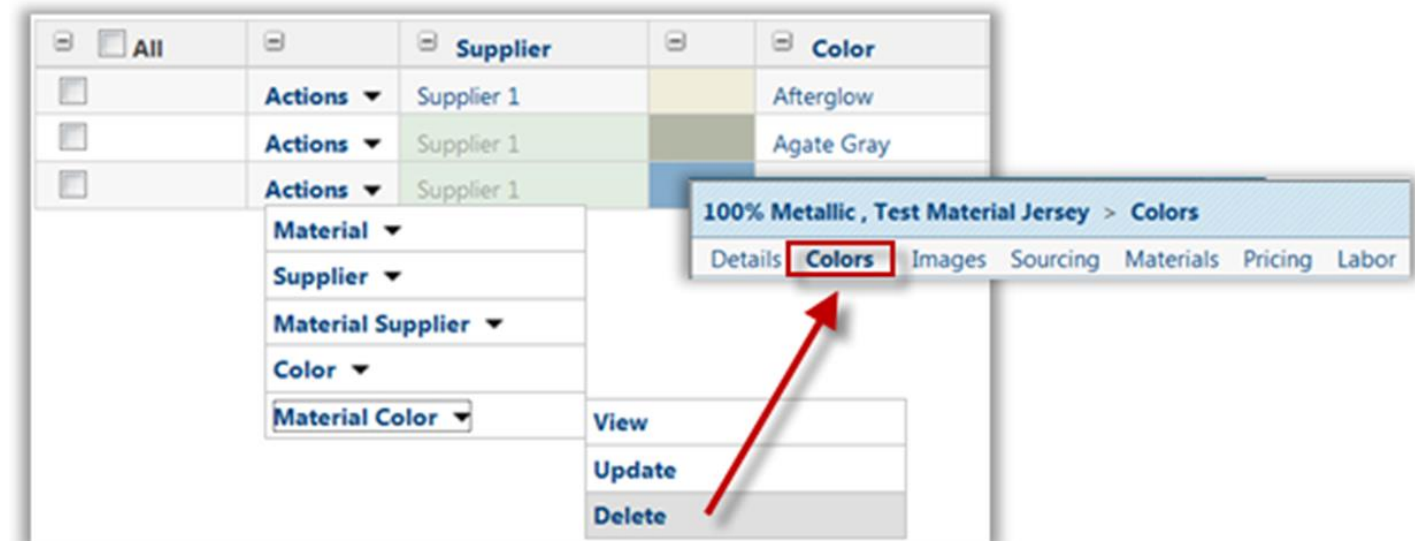

## Customer driven enhancements



- Create material-color sample from palette
- View material-color samples and attributes from palette
- Edit the name of product and colorway level line boards
- Export the line sheet to Excel, including line sheet name
- Remove multiple components from a spec
- Better system navigation after deleting a material-color
- **Remove default check for update measurement set**
- Better messaging for Update POMs and Re-apply POMs buttons
- Add a material (without a thumbnail) to a design card

## Key Features

- A new check box column in the spec components table enables the selection of components to be removed
- A *Remove Components* action added to the drop down provides the ability to remove all selected components in one click.

## Value

- Users no longer need to use the row drop down action to remove one component at a time

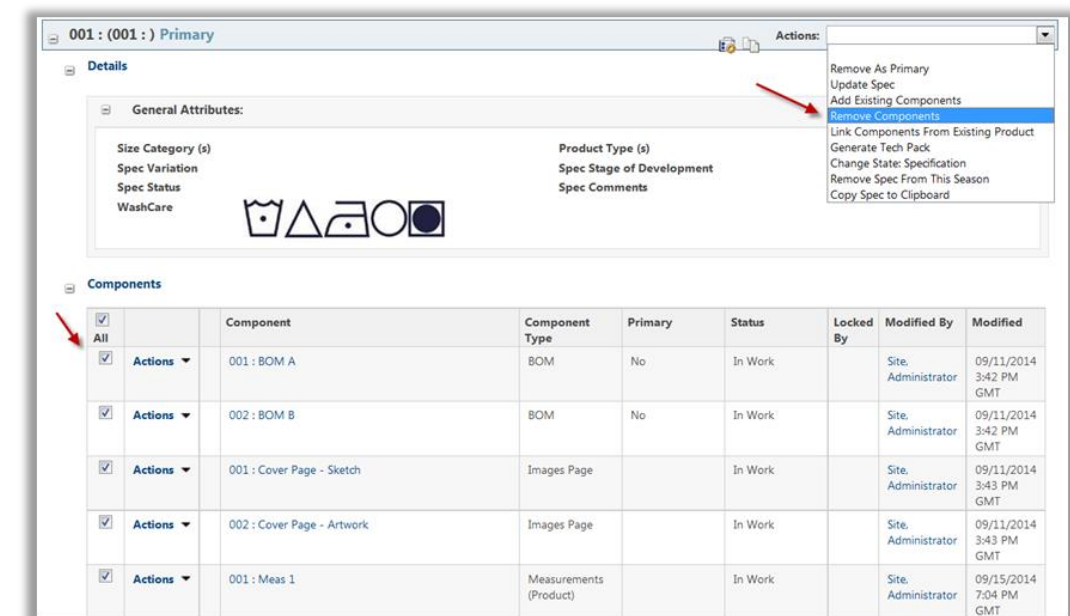

## Customer driven enhancements



- Create material-color sample from palette
- View material-color samples and attributes from palette
- Edit the name of product and colorway level line boards
- Export the line sheet to Excel, including line sheet name
- Remove multiple components from a spec
- Better system navigation after deleting a material-color
- Remove default check for update measurement set
- **Better messaging for Update POMs and Re-apply POMs buttons**
- Add a material (without a thumbnail) to a design card

## Key Features

- Both buttons now have updated messaging to inform users of their usage and impacts.

## Value

- This will reduce errors since users will understand the system behavior and the risk of losing data when using the buttons.

Details | **Fit Information** | Documents | Image

**Fit Information** | Update POMs | Re-Apply POMs

Measurement Set Base Size: 8

| POM # | POM Name | Placement Amount | Placement Re | (+)  | Tol (-) |
|-------|----------|------------------|--------------|------|---------|
|       | POM 1    |                  |              | 0.25 | 0.25    |
|       | POM 1    |                  |              | 0.25 | 0.25    |

## Customer driven enhancements



- Create material-color sample from palette
- View material-color samples and attributes from palette
- Edit the name of product and colorway level line boards
- Export the line sheet to Excel, including line sheet name
- Remove multiple components from a spec
- Better system navigation after deleting a material-color
- Remove default check for update measurement set
- Better messaging for Update POMs and Re-apply POMs buttons
- **Add a material (without a thumbnail) to a design card**

## Key Features

- Drag-n-Drop materials without thumbnails from FlexPLM library

## Value

- Materials in development can be referenced by designers

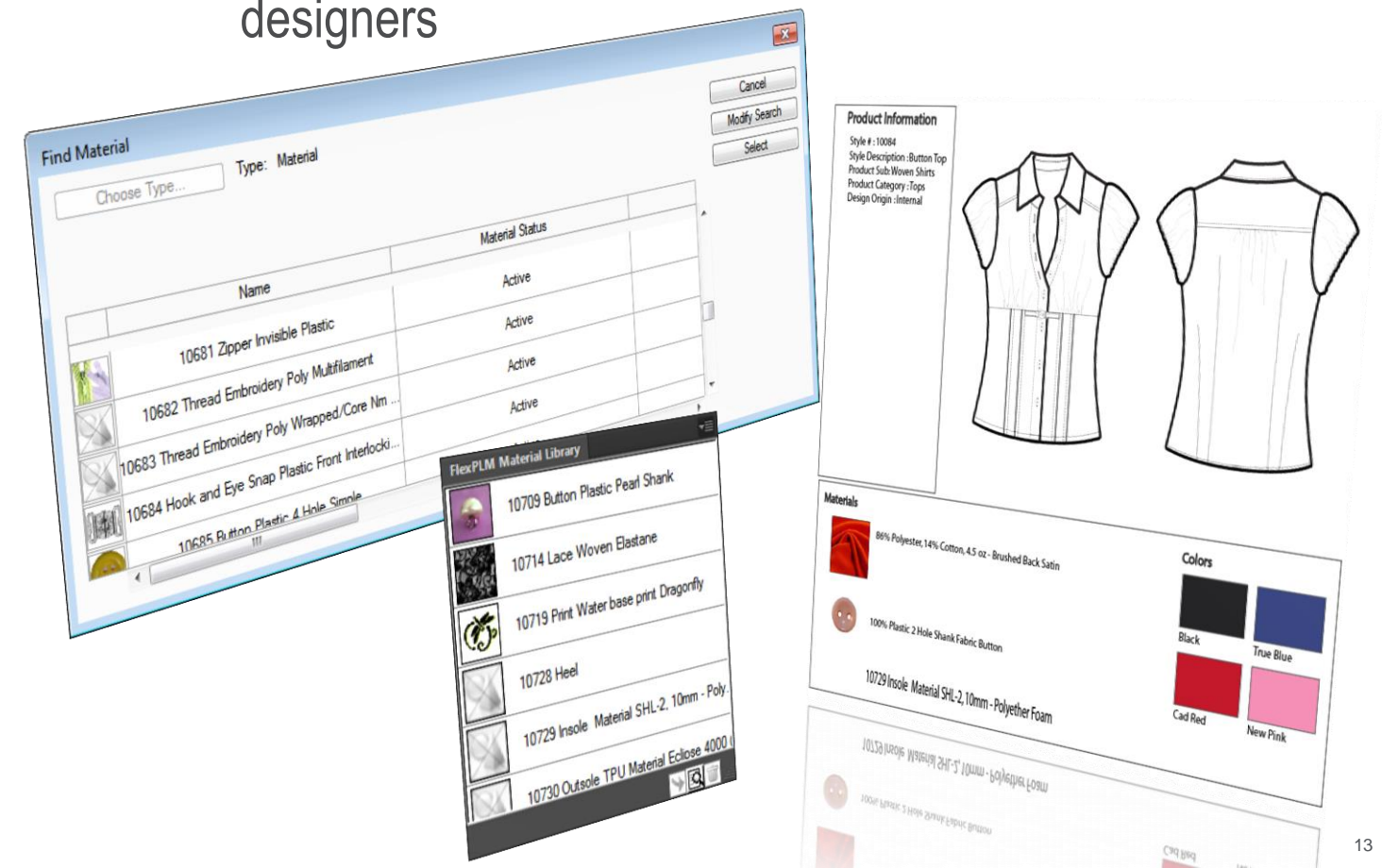

- FlexPLM Product SKU BOM Management with PDMLink EBOMs

- Season Management & Calendar Management
- Prototype Tech specs, planning and tracking
- Colorways and Hard/Soft BOM Management
- Suppliers & Sourcing Management
- Quality Management

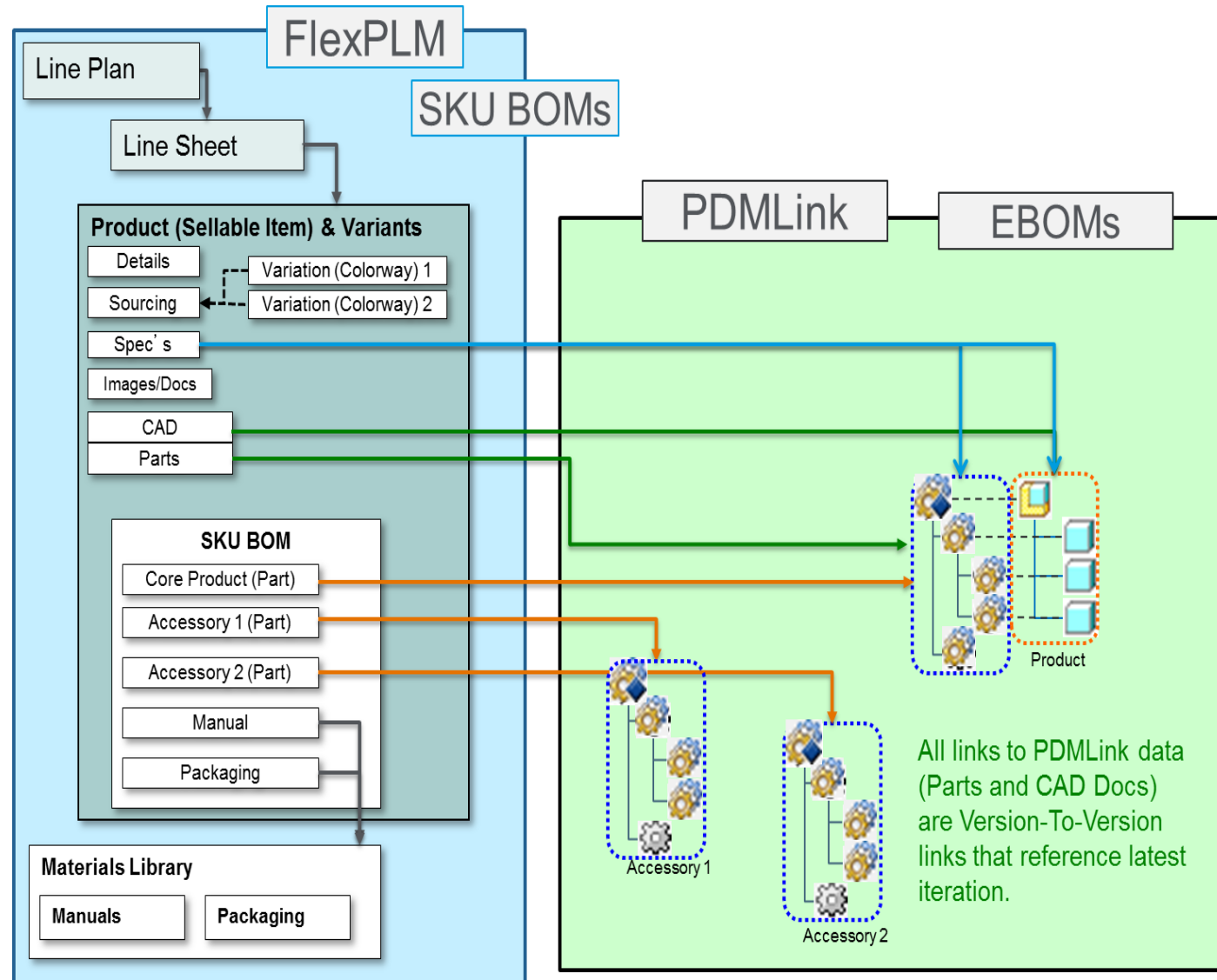

The screenshot shows the Windchill interface for product S56477. The top section displays product details and a Bill of Materials table. The BOM table lists components like lenses and accessories with their respective materials and suppliers. Below the BOM table is a table of colorway options. The bottom section shows a CAD model of sunglasses with dimension lines for 'temple (arm) length', 'lens width', 'distance between lenses', 'lens height', and 'total frame width'. A table below the CAD model lists colorway options.

| Component   | Mark Up | Material Id                                     | Material | Supplier | Status      |
|-------------|---------|---|----------|----------|-------------|
| S56477V_GUP |         | Shiny Full Dark Brown / Shiny Full Beige        |          |          | Standard    |
| S56477V_ALL |         | Shiny Havana / Shiny Crystal / Green / Blue     |          |          | Development |
| S56477_AHW  |         | Shiny Havana / Milky Orange / Shiny Full Yellow |          |          | Standard    |
| S56477_N58  |         | Shiny Crystal / Jeans Cloth / Shiny Crystal     |          |          | Standard    |

## Incremental Updates based on Feedback

- Upgraded to 10.2
- Process Changes
  - Product Sets\*
- Configuration Updates
  - Multiple updates to configuration based on customer feedback
- Reports
  - Calendar Dashboard option to compare to Product Target Dates in addition to Season Target Dates
  - Updates to
    - Material Aggregation Report – Colorway-level usage
    - Sample Tracking Report

| Health Status | Product ID                           | %    | Design Specification Released | 100.0% | Initial RFQs Sent | 90.9% | Vendor Selected | 72.7% |
|---------------|--------------------------------------|------|-------------------------------|--------|-------------------|-------|-----------------|-------|
| ⊟             |                                      |      | 09/27/2013                    |        | 10/24/2013        |       | 11/08/2013      |       |
| ⊟             | 236999 Hood Deflector Package        | 5.3  | 01/10/2014 ✓                  |        | 02/06/2014        |       | 02/21/2014      |       |
| ⊟             | 326250 Hitch - Ball Platform         | 26.3 | 01/09/2014 ✓                  |        | 01/09/2014 ✓      |       | 01/09/2014 ✓    |       |
| ⊟             | 356233 Paint Protection Film         | 21.1 | 01/09/2014 ✓                  |        | 01/09/2014 ✓      |       | 01/09/2014 ✓    |       |
| ⊟             | 411256 TRD Performance Exhaust       | 10.5 | 01/09/2014 ✓                  |        | 01/09/2014 ✓      |       | 01/23/2014      |       |
| ⊟             | 421452 TRD Quick Shifter             | 10.5 | 01/09/2014 ✓                  |        | 01/09/2014 ✓      |       | 01/23/2014      |       |
| ⊟             | 425612 TRD 16" Off-Road Alloy Wheel  | 5.3  | 01/09/2014 ✓                  |        | 01/29/2014        |       | 02/13/2014      |       |
| ⊟             | 462562 Security with GBS             | 10.5 | 01/09/2014 ✓                  |        | 01/09/2014 ✓      |       | 01/23/2014      |       |
| ⊟             | 562568 TRD Shift Knob - 6 spd Manual | 10.5 | 01/09/2014 ✓                  |        | 01/09/2014 ✓      |       | 01/23/2014      |       |
| ⊟             |                                      |      |                               |        |                   |       |                 |       |
| ⊟             | 100263 Cross Bars                    | 31.6 | 01/09/2014 ✓                  |        | 01/09/2014 ✓      |       | 01/09/2014 ✓    |       |
| ⊟             | 200451 Hood Deflector                | 21.1 | 01/09/2014 ✓                  |        | 01/09/2014 ✓      |       | 01/09/2014 ✓    |       |

- Two types of approach for any upgrade, regardless of version

- Migration
- Upgrade

- Leverage Windchill Upgrade tools to automate Windchill and FlexPLM upgrade tasks

- WinDU (Windchill Diagnostic Utility)
- Upgrade Manager

- Customization potentially impacted by API changes

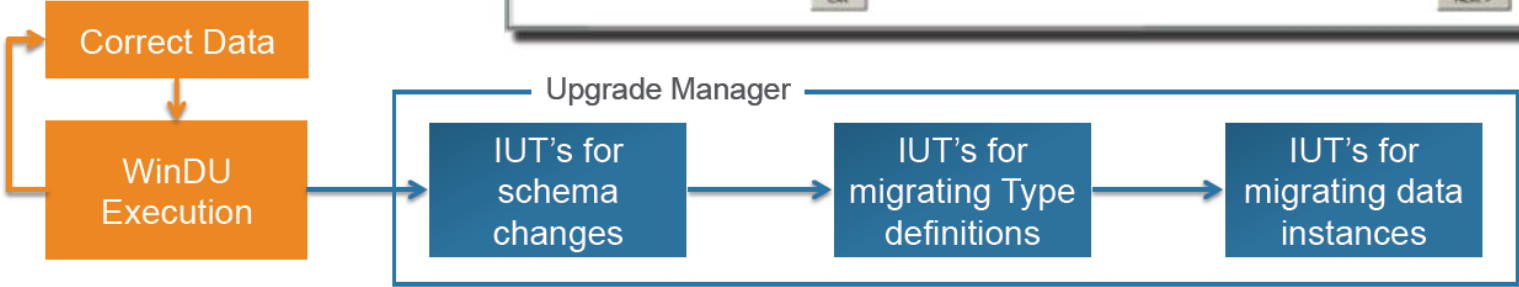
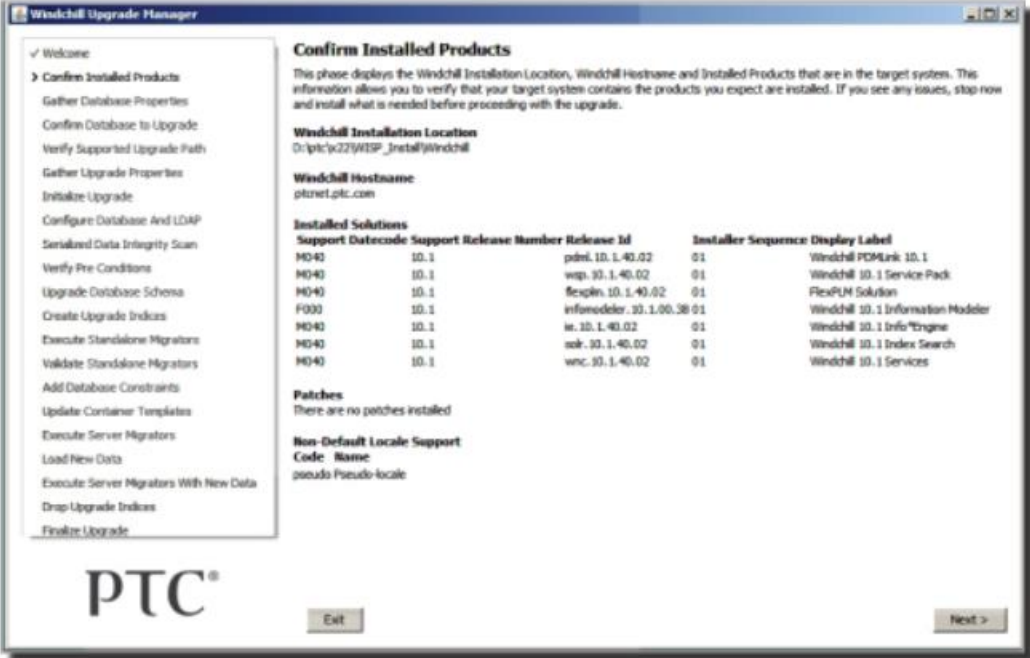

**Example WinDU's**

- Check Type names for uniqueness
- Detect attribute layout collisions
- Detect conflicting access control rules
- ...

**Example IUT's**

- Create new columns to support Windchill Type System (WTS)
- Load FlexPLM Types and other definitions into WTS
- ...

**Example IUT's**

- Transform customer Types (such as Season, Color, Product, etc) from FTS to WTS
- Transform Attribute Groups and Layouts
- Transform access control rules
- ...

**Example IUT's**

- Transform all instance data (such as Season, Color, Document, etc)
- Transform Filters and Views
- Transform Lists to Enumerations
- ...



Introducing “Extended Support” offering for FlexPLM 9.2 and up

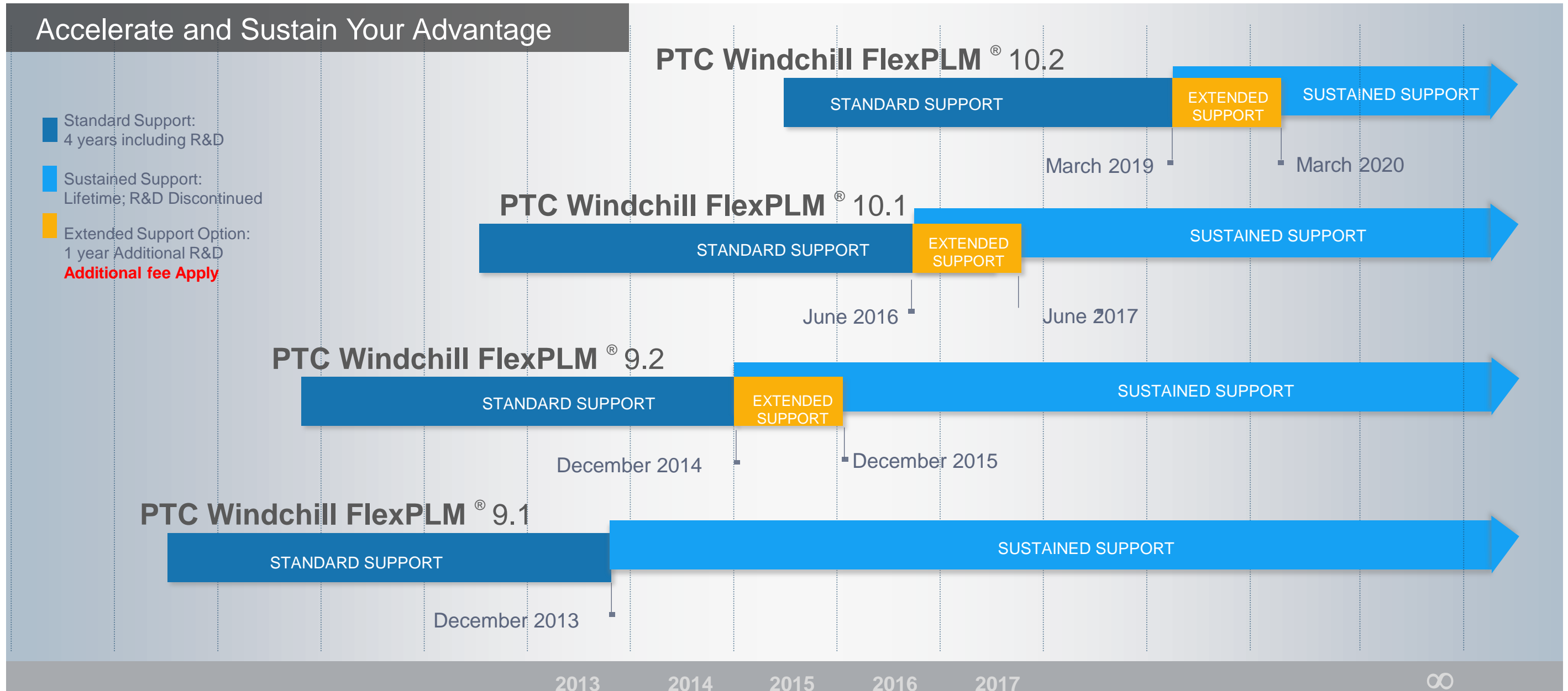

For more specific details, please visit the PTC Product Release Calendar  
[http://www.ptc.com/cs/product\\_calendar/PTC\\_Product\\_Calendar.htm](http://www.ptc.com/cs/product_calendar/PTC_Product_Calendar.htm)

## Vendor Portal

- Enabling different vendor collaboration models
  - Allow suppliers to create/edit Specification data for internally created Products
  - Allow suppliers to create their own Materials and Products and populate Spec data
  - Allow suppliers to create their own Colors and Artwork

- Managing Supplier-To-Supplier Relationships and Vendor Access
  - Manage supplier relationships depending on their roles
    - Enable data access to products, specs, materials, colors



Usability / User Experience : Parallel track of evolution and Innovation

## Current FlexPLM application

- Evolve with incremental improvements prioritized by user community
  - Sample Management
  - Freeze Panes

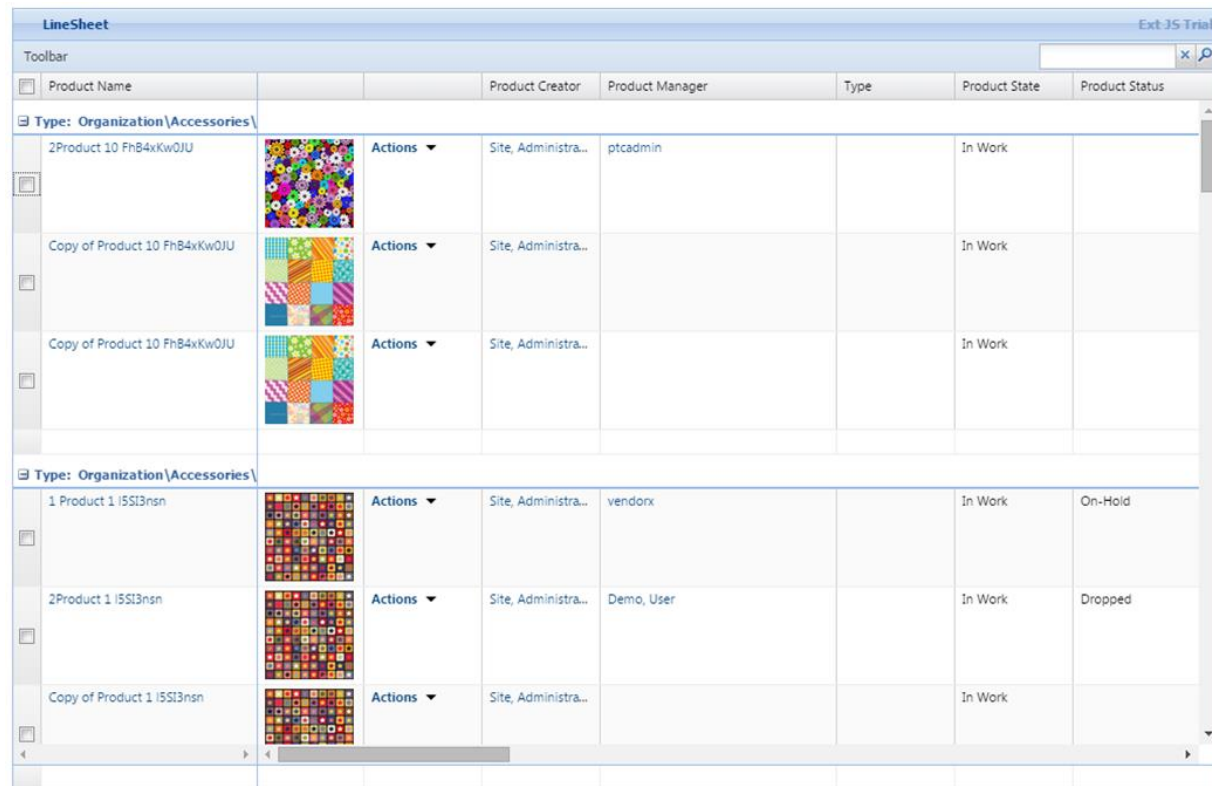

## Role Based / Task Based Apps



- Decouple backend tier with UI to maintain scalability, performance, flexibility and security
- Develop role-based apps that will eventually replace monolithic UI

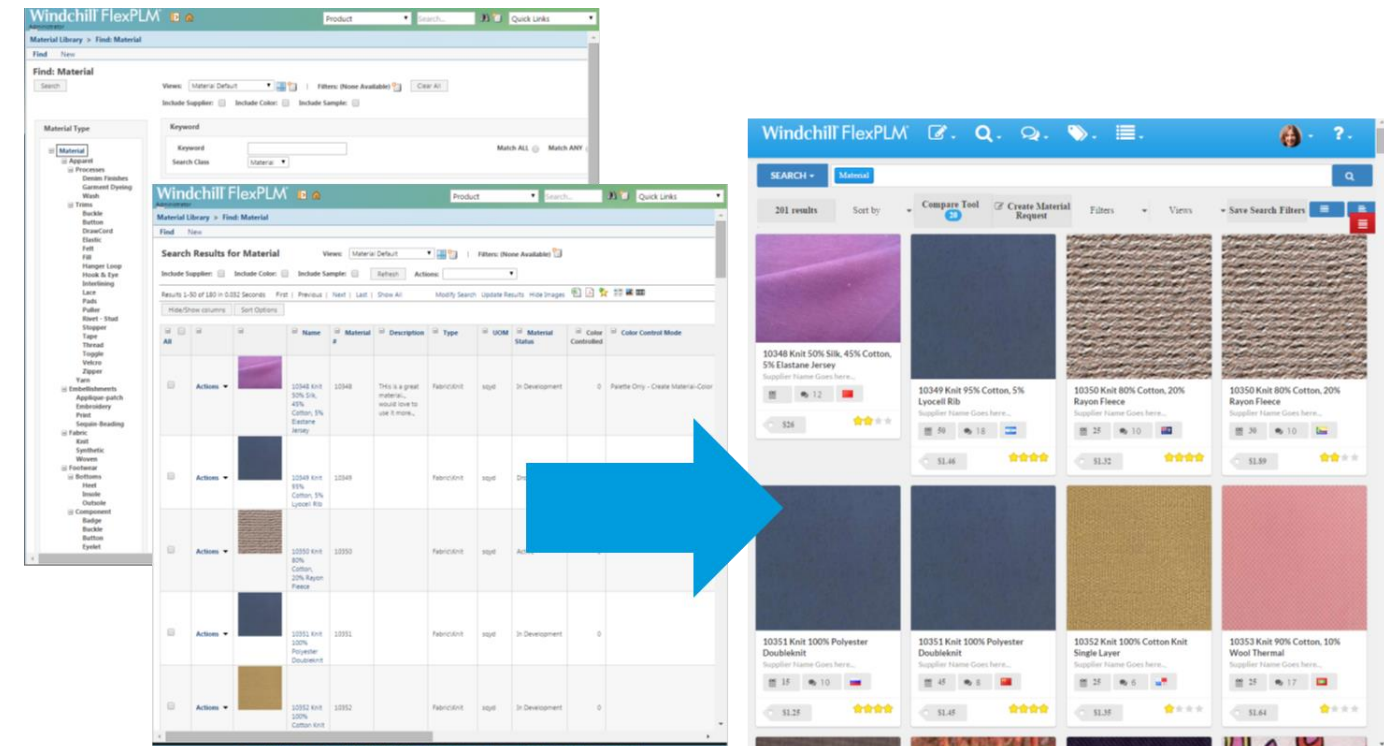

Usability / User Experience : Parallel track of evolution and Innovation

## Current FlexPLM application

- Evolve with incremental improvements prioritized by user community

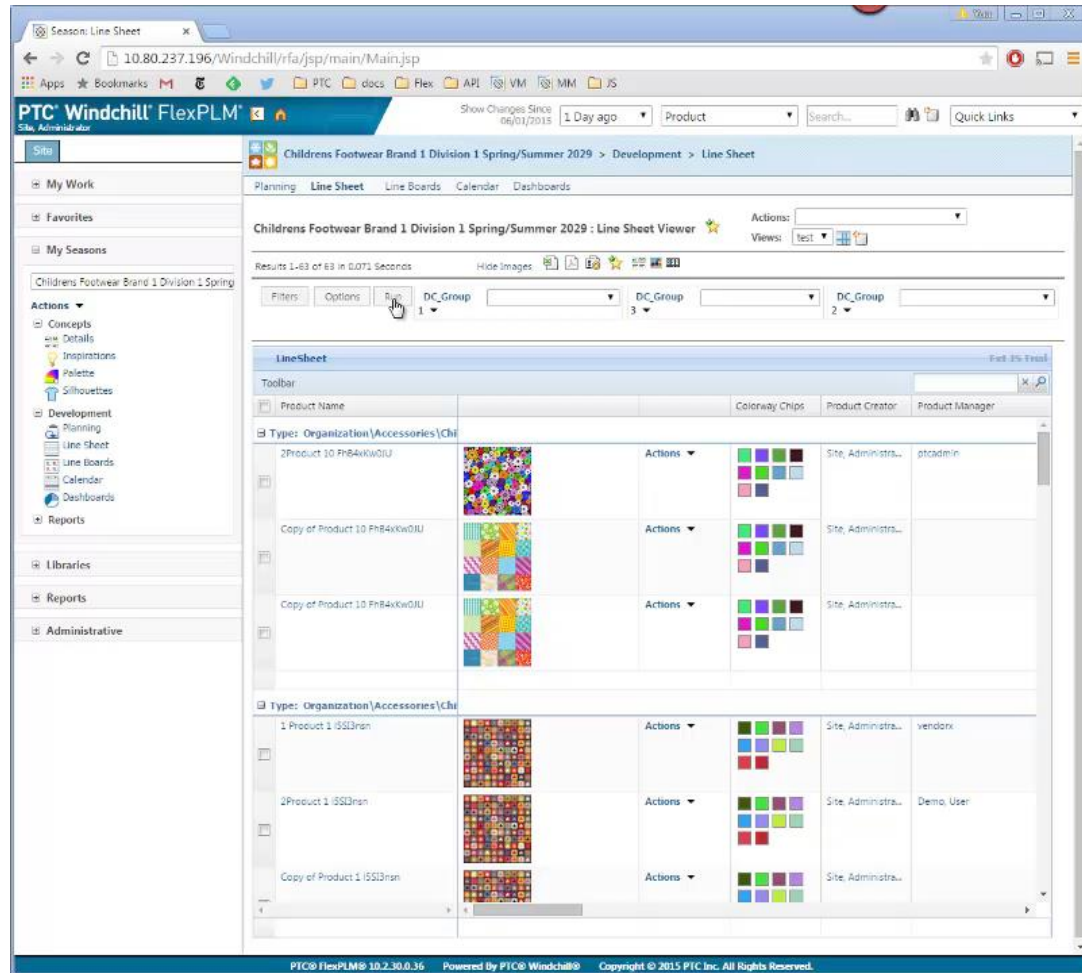

## Role Based / Task Based Apps



- Decouple backend tier with UI to maintain scalability, performance, flexibility and security
- Develop role-based apps that will eventually replace monolithic UI

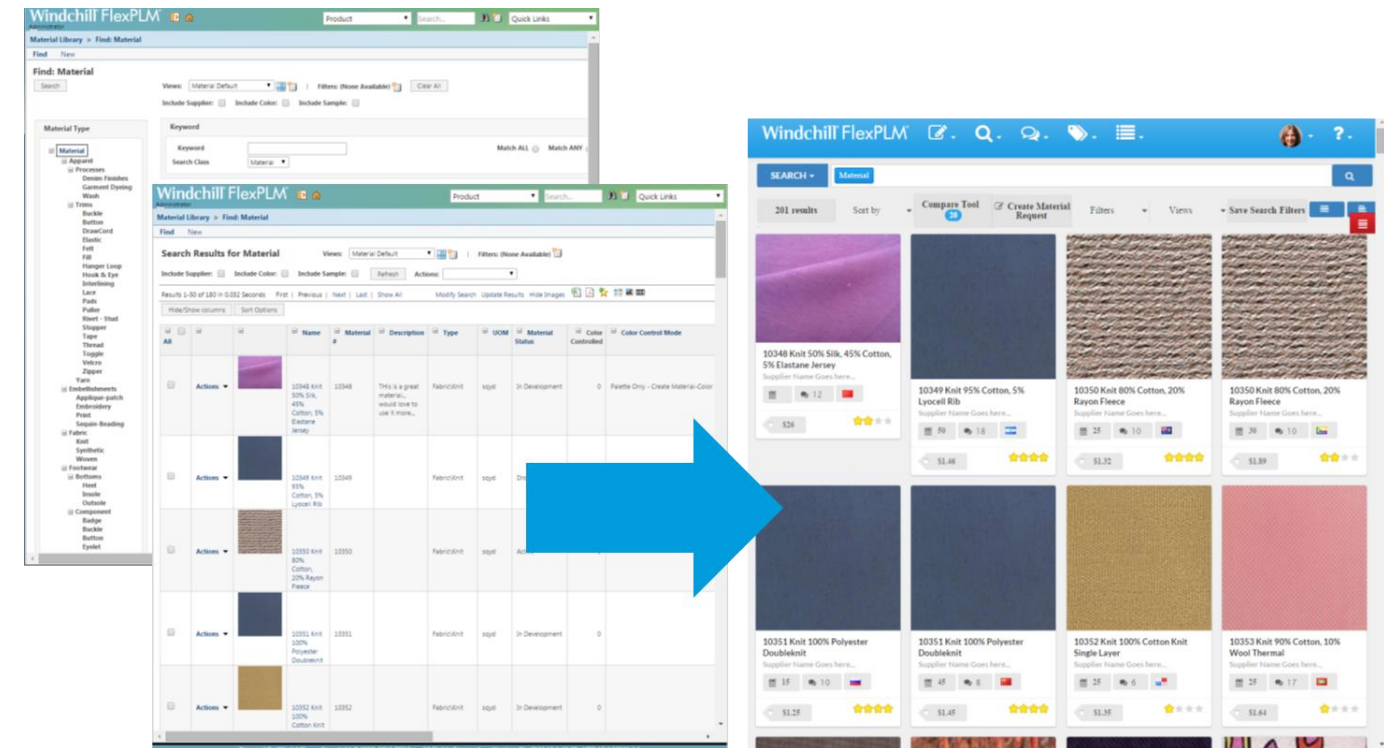

Usability / User Experience : Parallel track of evolution and Innovation

## Current FlexPLM application

- Evolve with incremental improvements prioritized by user community
  - Sample Management
  - Freeze Panes

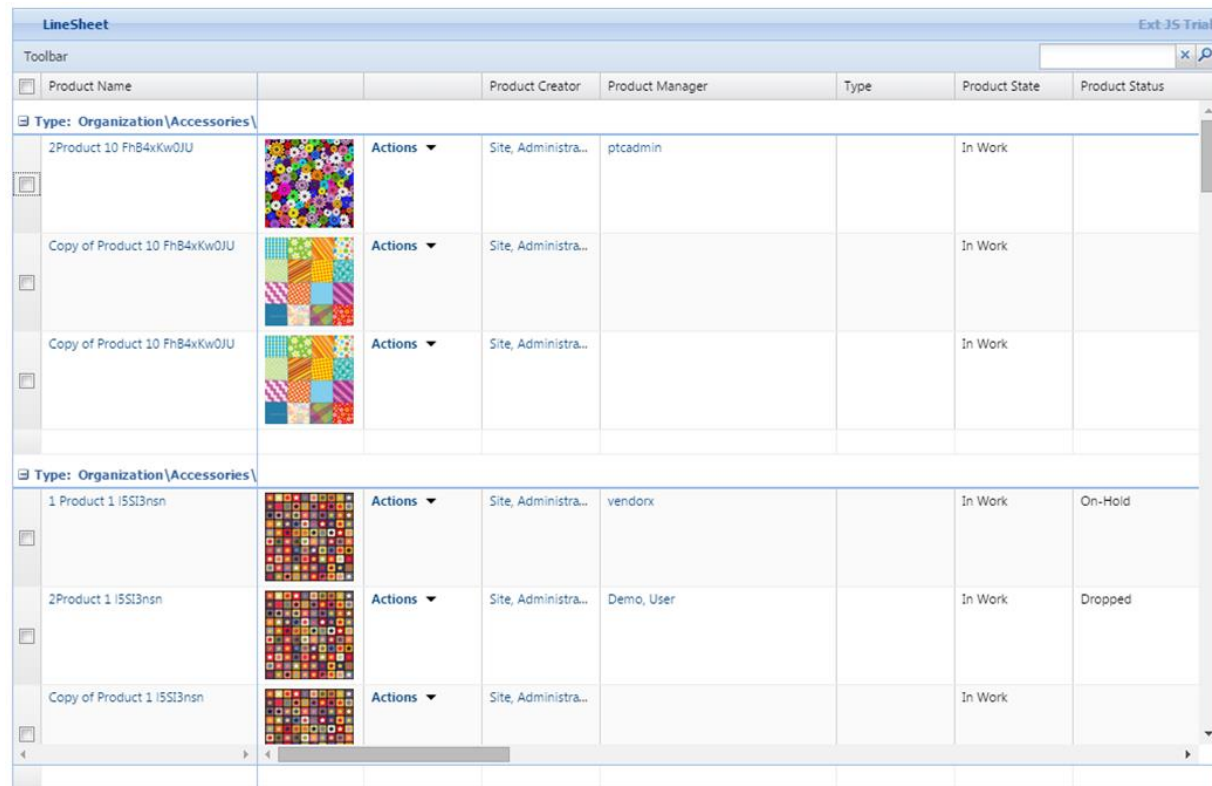

## Role Based / Task Based Apps



- Decouple backend tier with UI to maintain scalability, performance, flexibility and security
- Develop role-based apps that will eventually replace monolithic UI

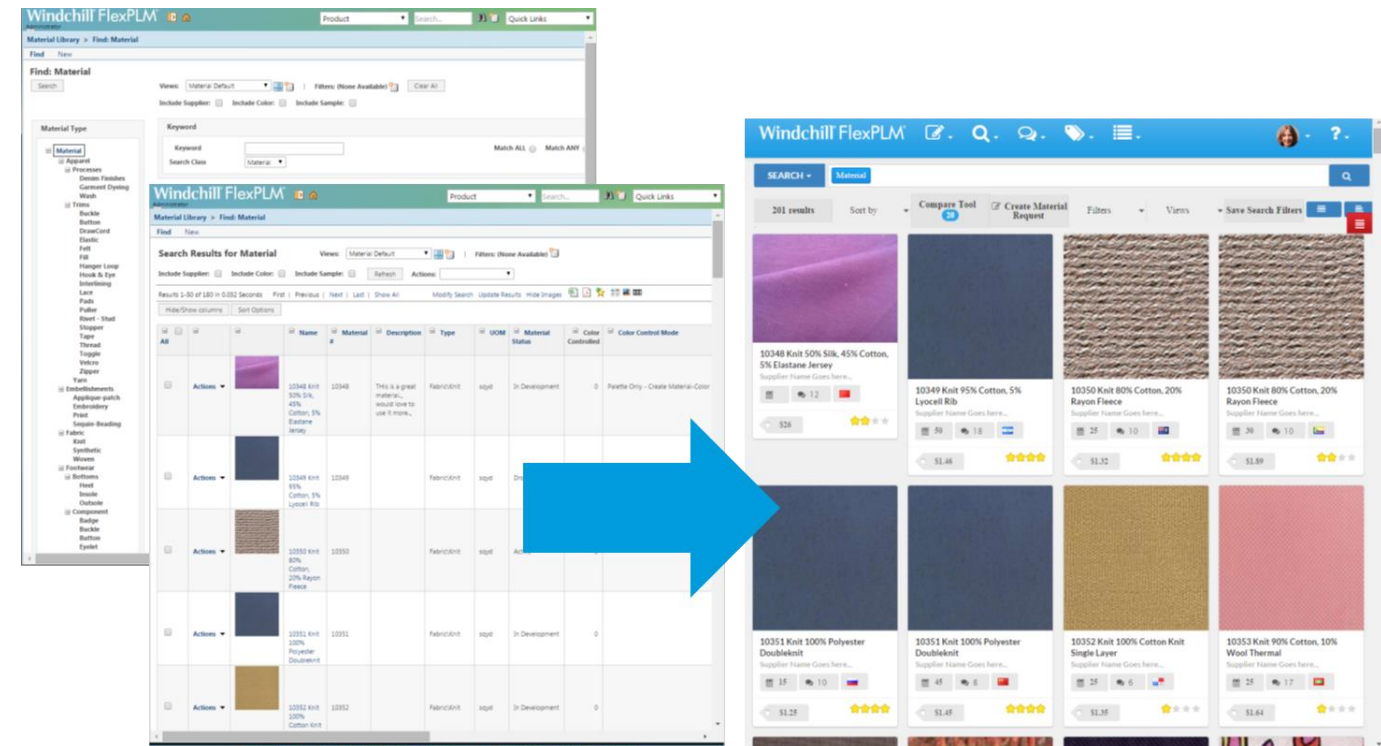

Usability / User Experience : Parallel track of evolution and Innovation

## Current FlexPLM application

- Evolve with incremental improvements prioritized by user community
  - Sample Management
  - Freeze Panes

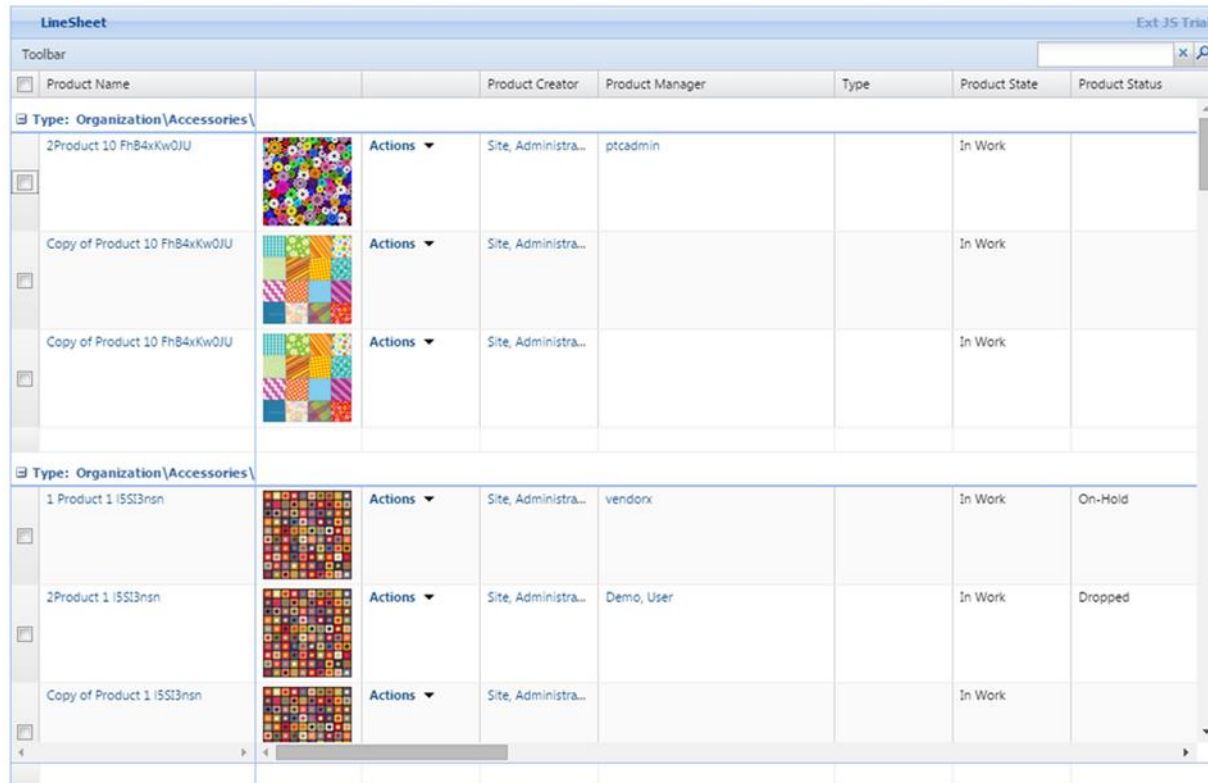

| Product Name                    | Product Creator     | Product Manager | Type | Product State | Product Status |
|---------------------------------|---------------------|-----------------|------|---------------|----------------|
| Type: Organization\Accessories\ |                     |                 |      |               |                |
| 2Product 10 FhB4xKw0JU          | Site, Administra... | ptcadmin        |      | In Work       |                |
| Copy of Product 10 FhB4xKw0JU   | Site, Administra... |                 |      | In Work       |                |
| Copy of Product 10 FhB4xKw0JU   | Site, Administra... |                 |      | In Work       |                |
| Type: Organization\Accessories\ |                     |                 |      |               |                |
| 1 Product 1 ISSI3nsn            | Site, Administra... | vendorx         |      | In Work       | On-Hold        |
| 2Product 1 ISSI3nsn             | Site, Administra... | Demo, User      |      | In Work       | Dropped        |
| Copy of Product 1 ISSI3nsn      | Site, Administra... |                 |      | In Work       |                |

## Role Based / Task Based Apps

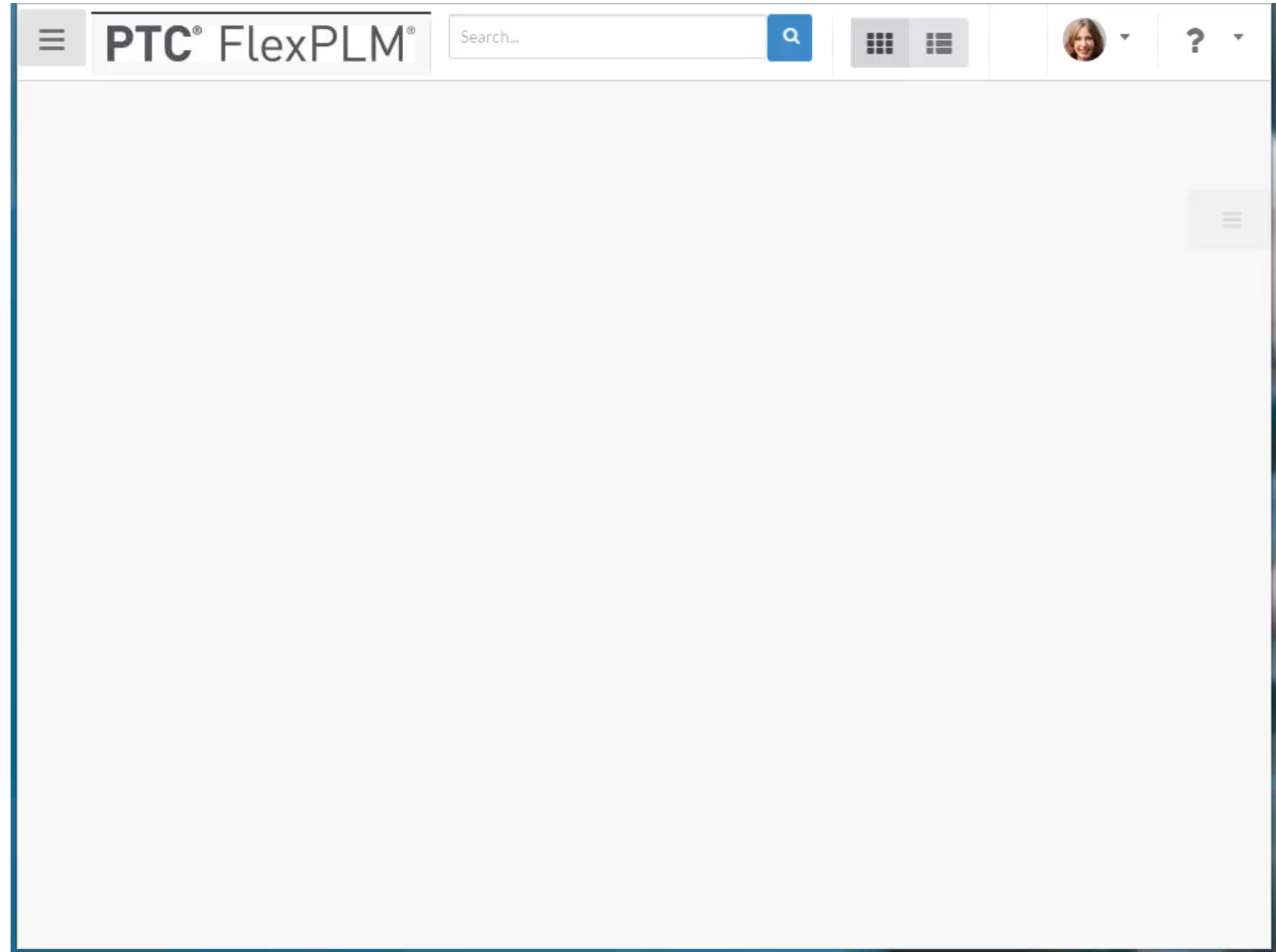



Innovation  
Demands



Market  
Demands



Cost  
Demands

**Technology Trends**

**Competition**

**Personalized Products**

**Omni-Channel**

**Voice Of the Customers**

**Region specific Needs**

**Rising Raw Material Cost**

**Development Cost**

**Compliance & Sustainability  
requirements**

# Looking Forward – Product Development Innovation

## “Material First” Development in PLM

Manage critical material development steps in parallel to product development

### Material Development Process

#### Plan

| Program # | Program Description | Dept                               | Units  | In Store Date |
|-----------|---------------------|------------------------------------|--------|---------------|
| 2947027   | Woven Tops          | Womens                             | 10,000 | 2/1/15        |
|           | Fabric Need:        | Poly cotton blend                  |        |               |
| 4832658   | Knit Tops           | Womens                             | 8,000  | 2/1/15        |
|           | Fabric Need:        | Merino wool, cashmere / silk blend |        |               |
| 5876246   | Knit Tops           | Mens                               | 8,500  | 3/1/15        |
|           | Fabric Need:        | Merino wool, cotton                |        |               |



Materials can be developed / sourced in parallel to product spec development. When appropriate, selected materials can be inserted in product BOMs within impending development of those BOMs.

#### Plan

| Program # | Program Description | Dept                        | Units  | In Store Date |
|-----------|---------------------|-----------------------------|--------|---------------|
| 2947027   | Woven Tops          | Womens                      | 10,000 | 2/1/15        |
|           | Styles:             | Short sleeve ruffled blouse |        |               |
|           |                     | Long sleeve ruffled blouse  |        |               |
| 4832658   | Knit Tops           | Womens                      | 8,000  | 2/1/15        |
|           | Styles:             | Crew neck sweater           |        |               |
|           |                     | V-neck sweater              |        |               |
|           | Fabric Need:        | Sweater shawl               |        |               |
| 5876246   | Woven Tops          | Mens                        | 8,500  | 3/1/15        |
|           | Styles:             | Henley sweater              |        |               |



#### Develop (BOM)

| Component            | Mark Up | Material ID | Material   | Supplier        | Color    | Standard Price | Material Price |
|----------------------|---------|-------------|--|-----------------|----------|----------------|----------------|
| <b>Fabric</b>        |         |             |  |                 |          |                |                |
|                      |         |             | 86% Polyester, 14% Cotton, 4.5 oz - Brushed Back Satin | GETZNER TEXTLAG |          | \$2.15         | \$1.51         |
| Fabric Piece         |         | FWO-100000  |  |                 |          |                |                |
|                      |         |             | 100% Cotton, 3 oz - Chambray                           | PATTU FABRICS   | Brunette | \$1.50         | \$1.65         |
| Collar Reinforcement | New     | FWO-102928  |  |                 |          |                |                |
| <b>Trims</b>         |         |             |  |                 |          |                |                |
|                      |         |             | 100% Plastic 4 Hole Button                             | THREADTEX INC.  | Red Plum | \$0.05         | \$0.12         |
| Button               |         | TCL-100001  |  |                 |          |                |                |

### Product Development Process



# Looking Forward – Product Development Innovation

## Manage the complete Product Digital definition

- 3D Central to product definition

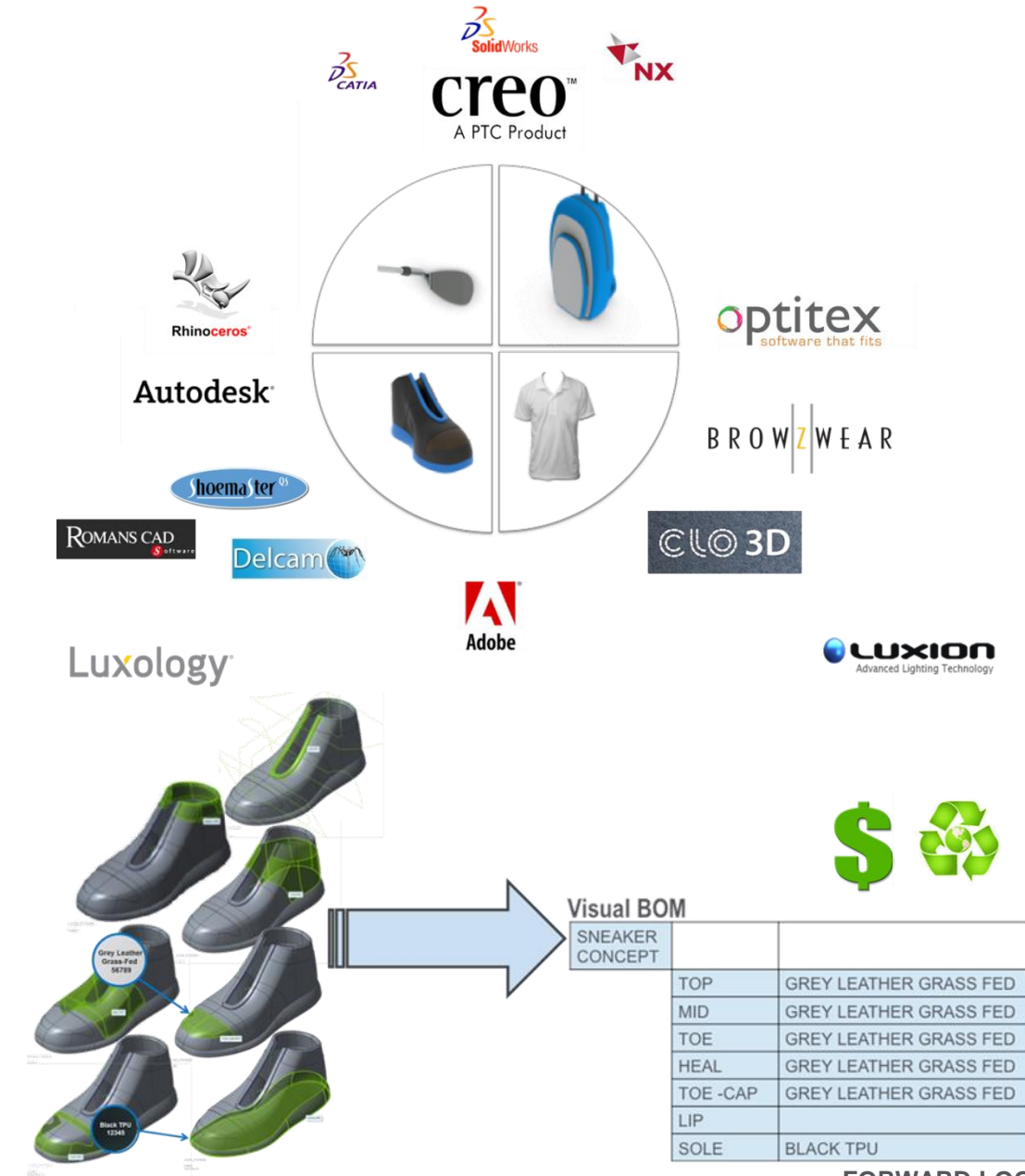

- Product Complexity is increasing

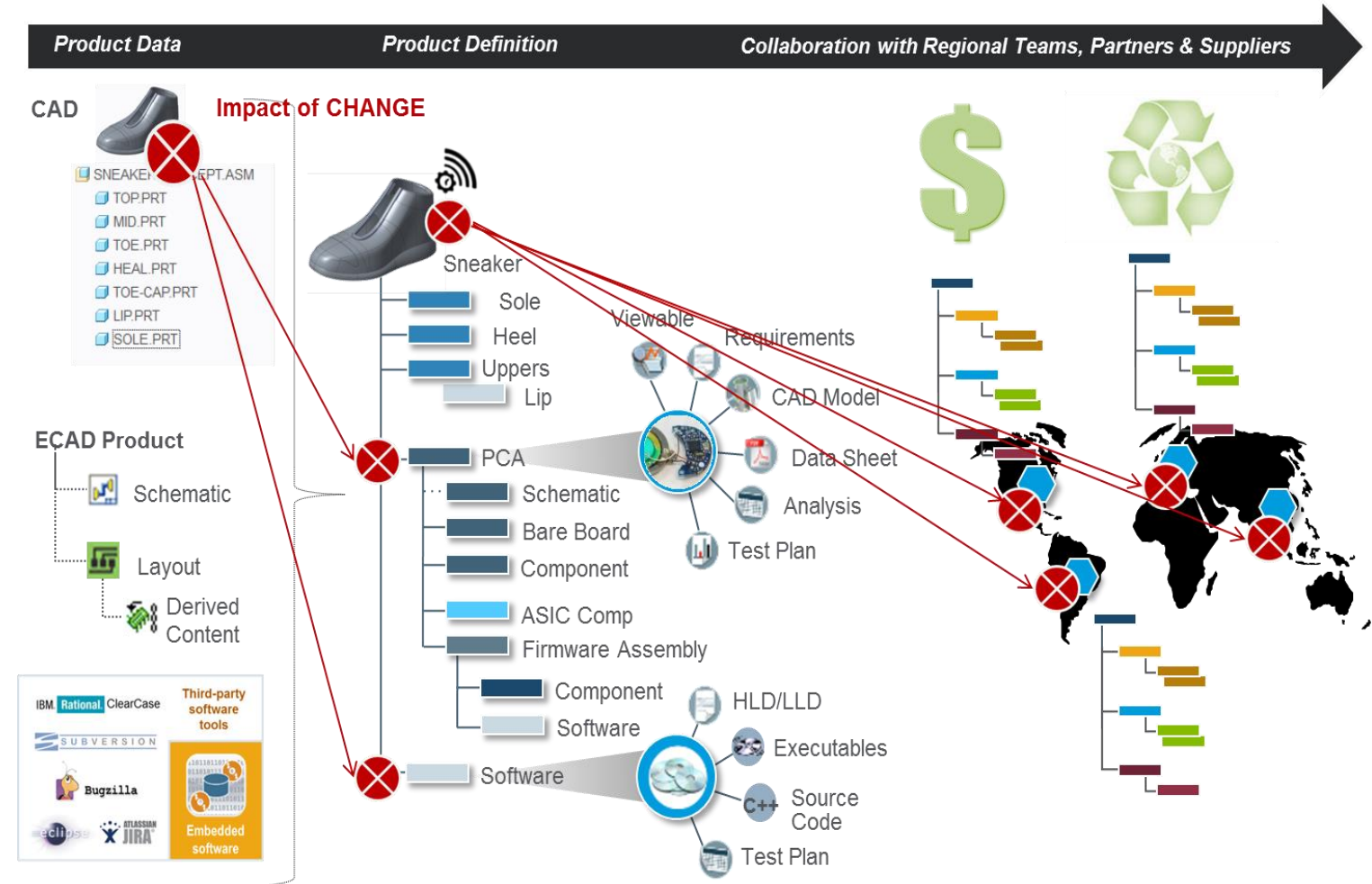

# Looking Forward – Product Development Innovation

## Manage the complete Product Digital definition

- 3D Central to product definition

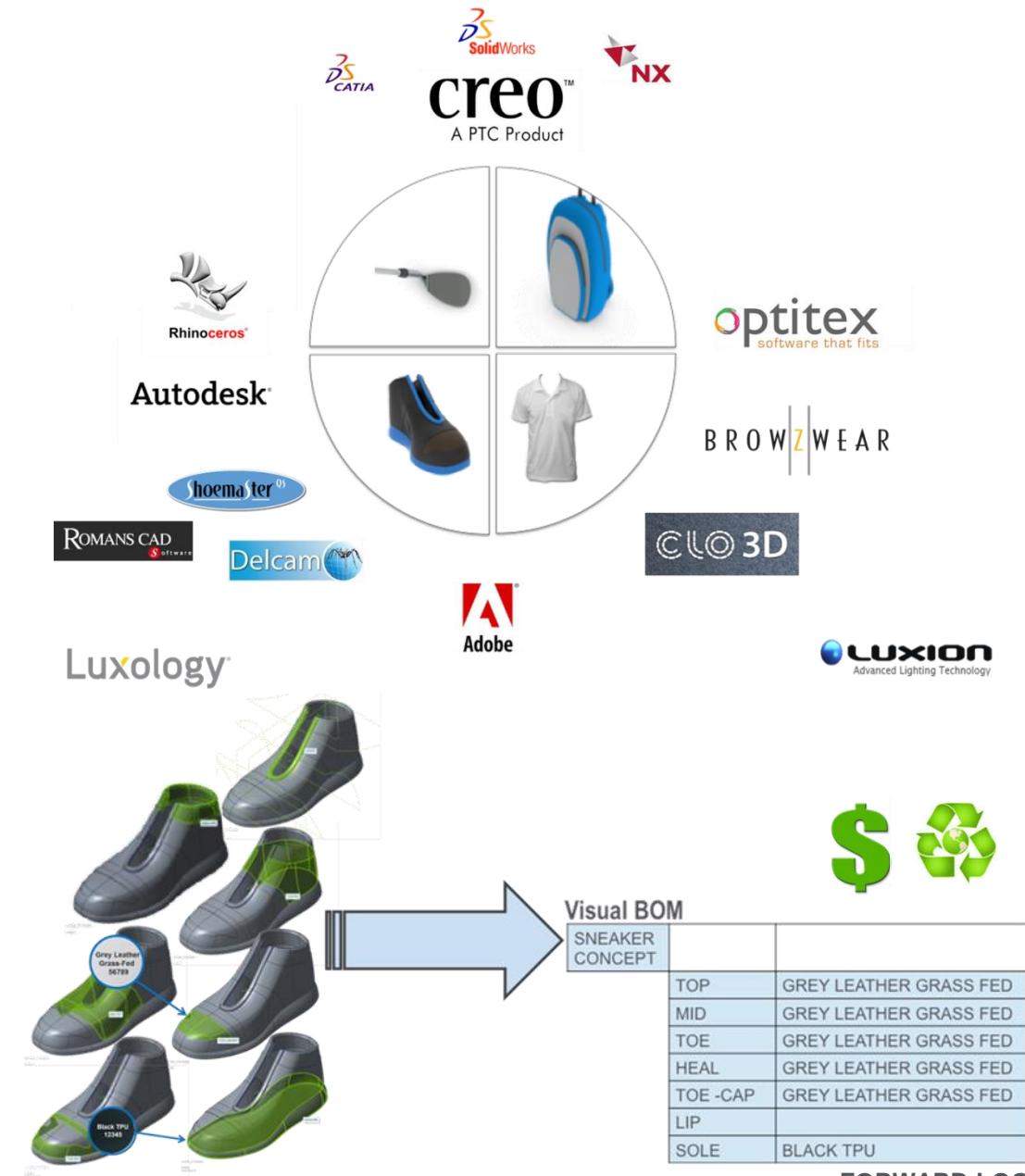

- Product Complexity is increasing



# Looking Forward – Product Development Innovation

## “Product performance insight” for Innovation

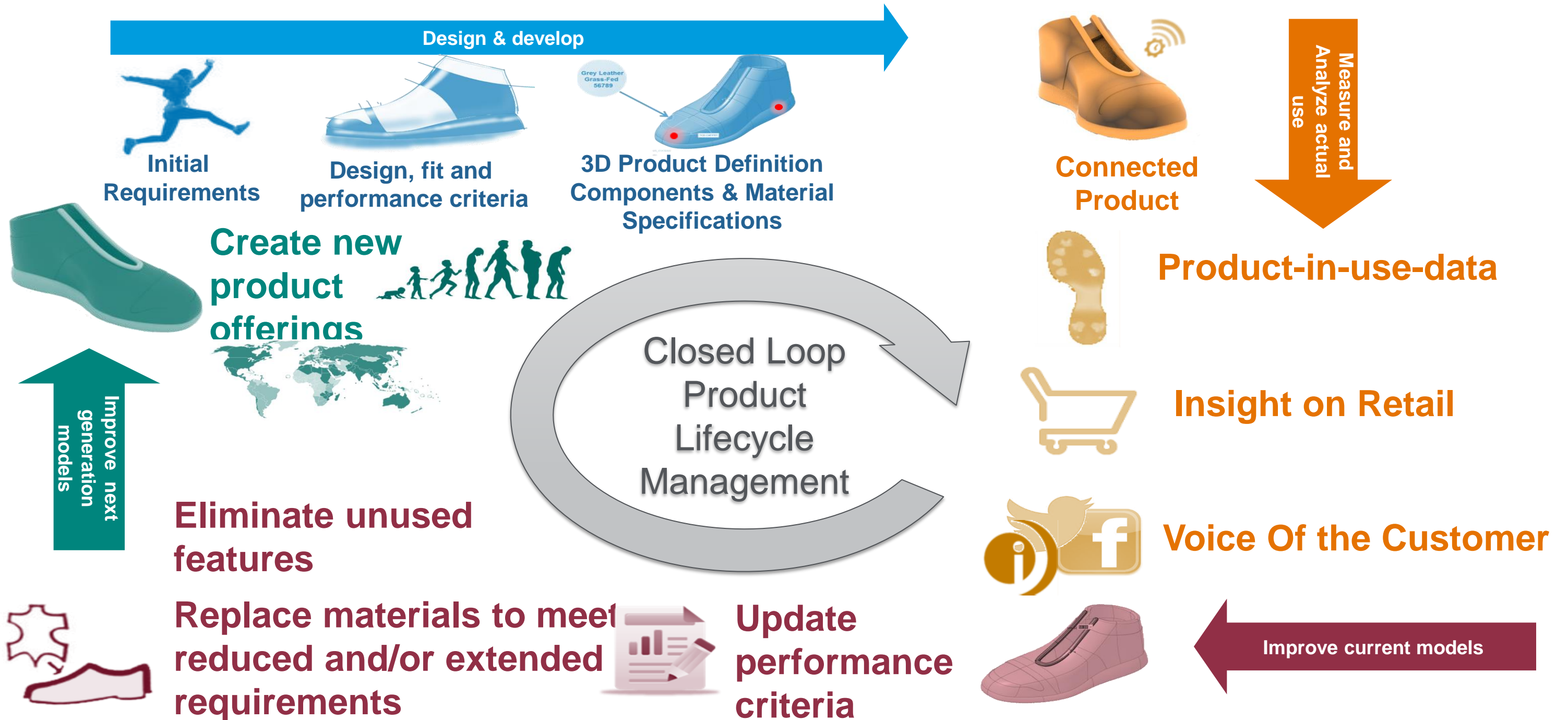

Expanding breadth through Partnership – Voice Of the Customer



**Track trends, identify winning products, and predict demand**  
 ...by seamlessly incorporating VOC into the product development process

Consumer test hundreds to thousands of products within 48-72

Integrate First Insight Product and Pricing recommendations into FlexPLM to support Line Review & Design adjustments

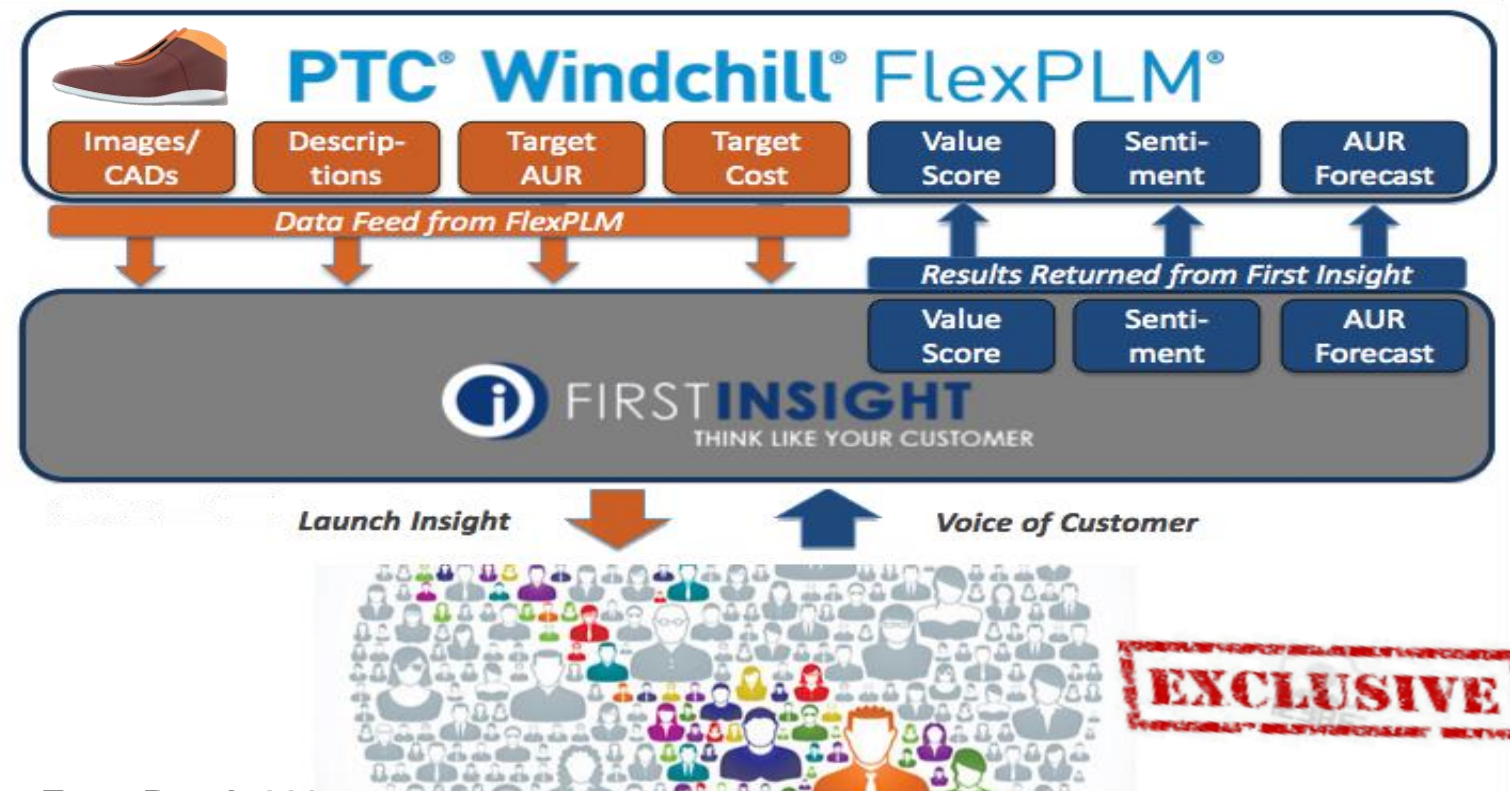
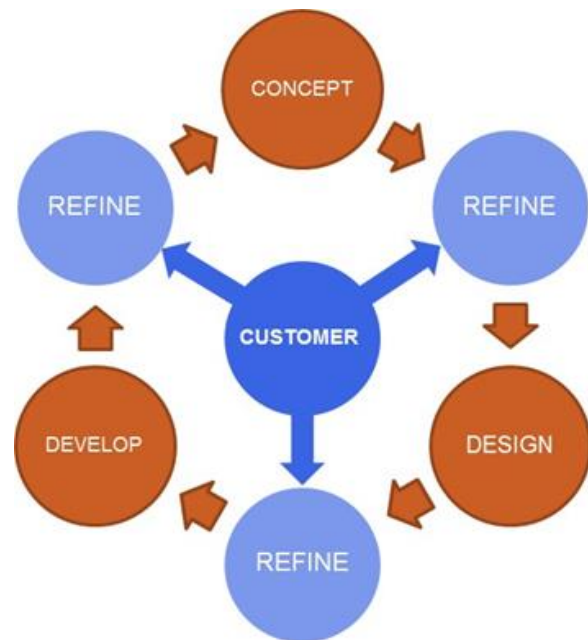

## FlexPLM Mobile Application

- Free Apps for Photo Capture on Apple Store
  - Updated on March 2015
  - Integration kit available on PTC Community or through ITC
- **Advanced Apps** available through ITC
  - Utility : Search, Tasks, Product Creation
  - On- and Off-line Product season catalog review
  - Sample management , now with **QR code support**
- Customization services provided by
 
- Minimum System requirements : FlexPLM 10.1 and iOS 7.1

Image Capture Mobile Apps Use Case



Image Capture Mobile Apps Use Case

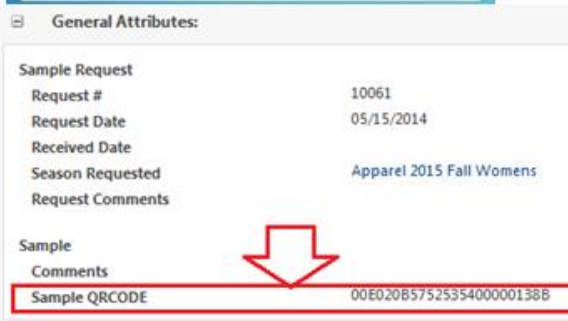
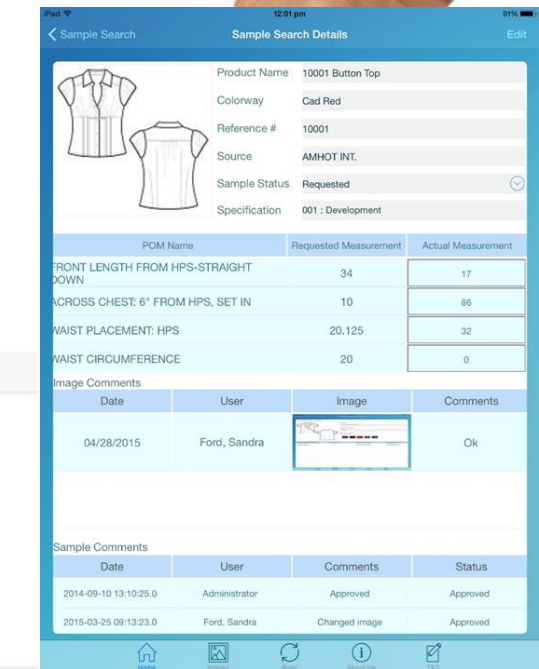
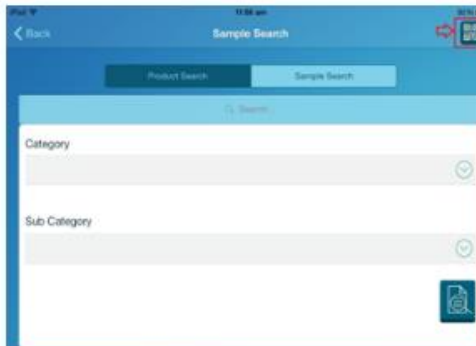
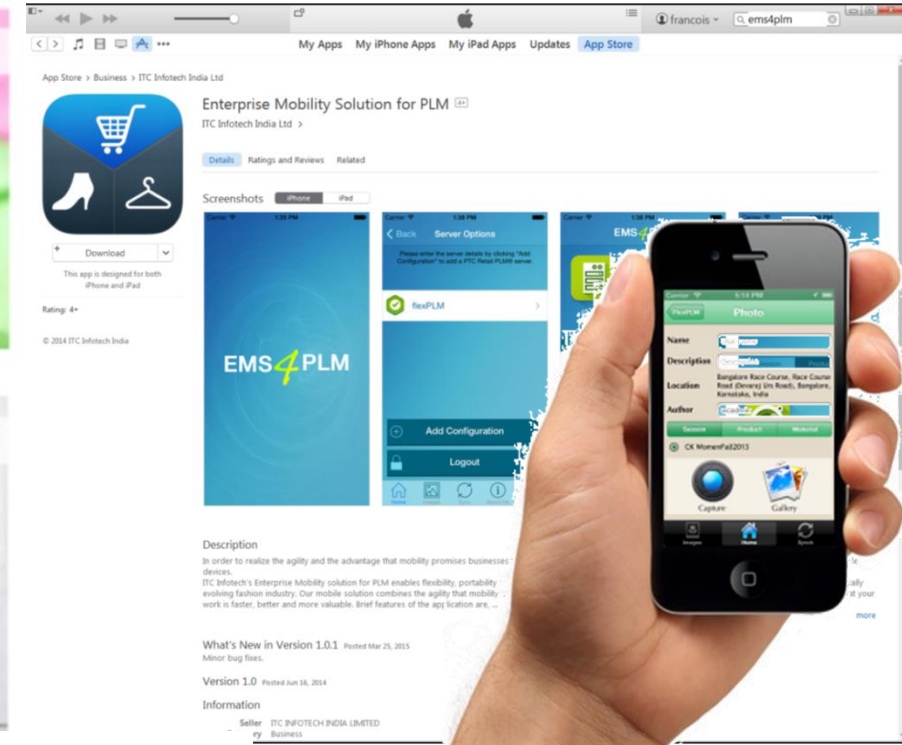

Full scope of retail services from innovation strategy through PLM transformation and IoT enablement

- **Smart Connected Store – Booth 237**
  - Real-time shopping experience
  - Showcasing benefits to customer and retailer
  - Extract more actionable insights from WHAT YOU ALREADY HAVE
- **Services for Enabling Retail Connectivity**
  - Connect systems, assets and people
  - Extract insight and drive business value
- **IoT Smart Start Services**
  - Enable your smart, connected products vision
  - Prove the business value
  - Prove the technology



Accelerate  
the **Path to  
Value** with

**KALYPSO**  
+  
**ThingWorx**  
A PTC® Business

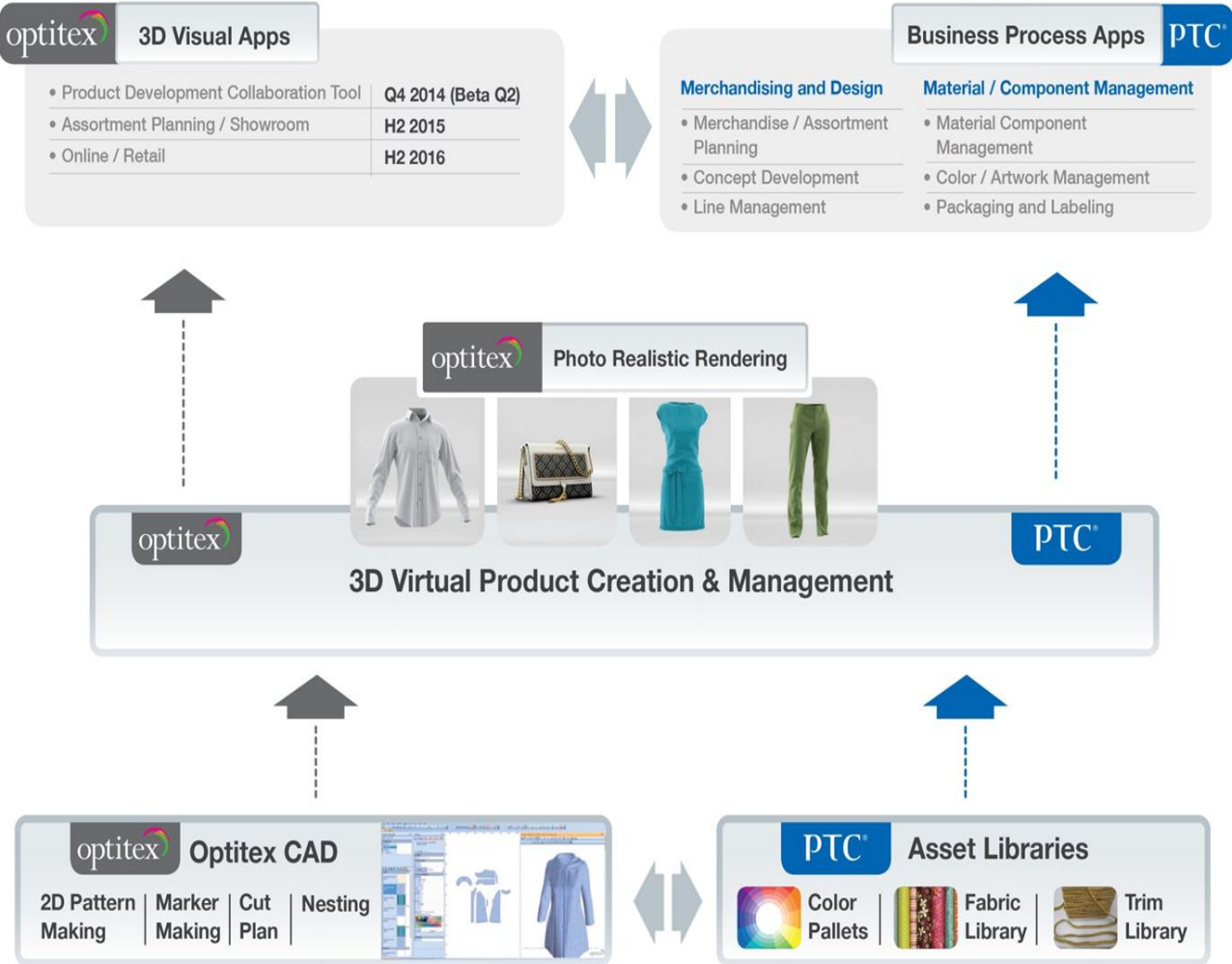

PLUGIN76

- Plugin76 specializes in plugin and workflow solutions for Fashion, Design and PLM
- “Pimobo” a web-based “inspiration board” tool aggregating data from social streams







- Your feedback is valuable
- Don't miss out on the chance to provide your feedback
- Gain a chance to win an instant prize!
- Complete your session evaluation now

# PTC<sup>®</sup> Live Global