

REVISIONS		
REV	DESCRIPTION	
A	CLASS A RELEASE	SEE PDMS

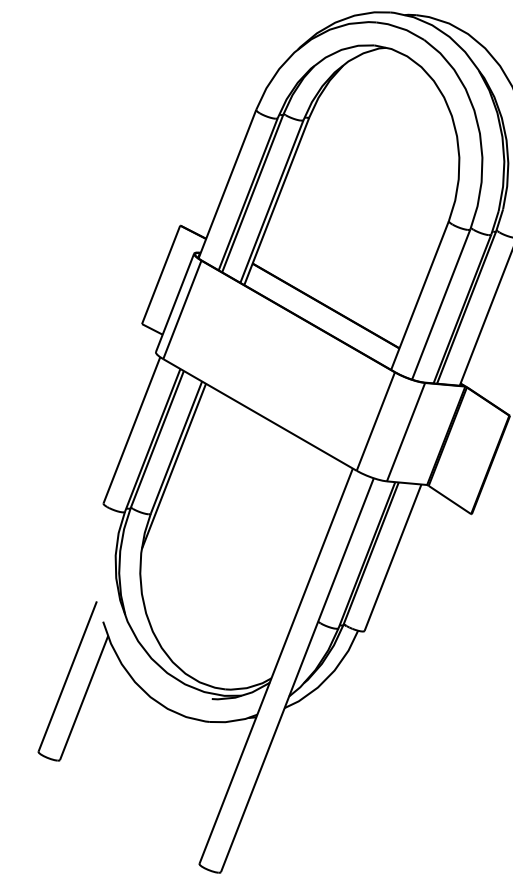

SCALE 3:4

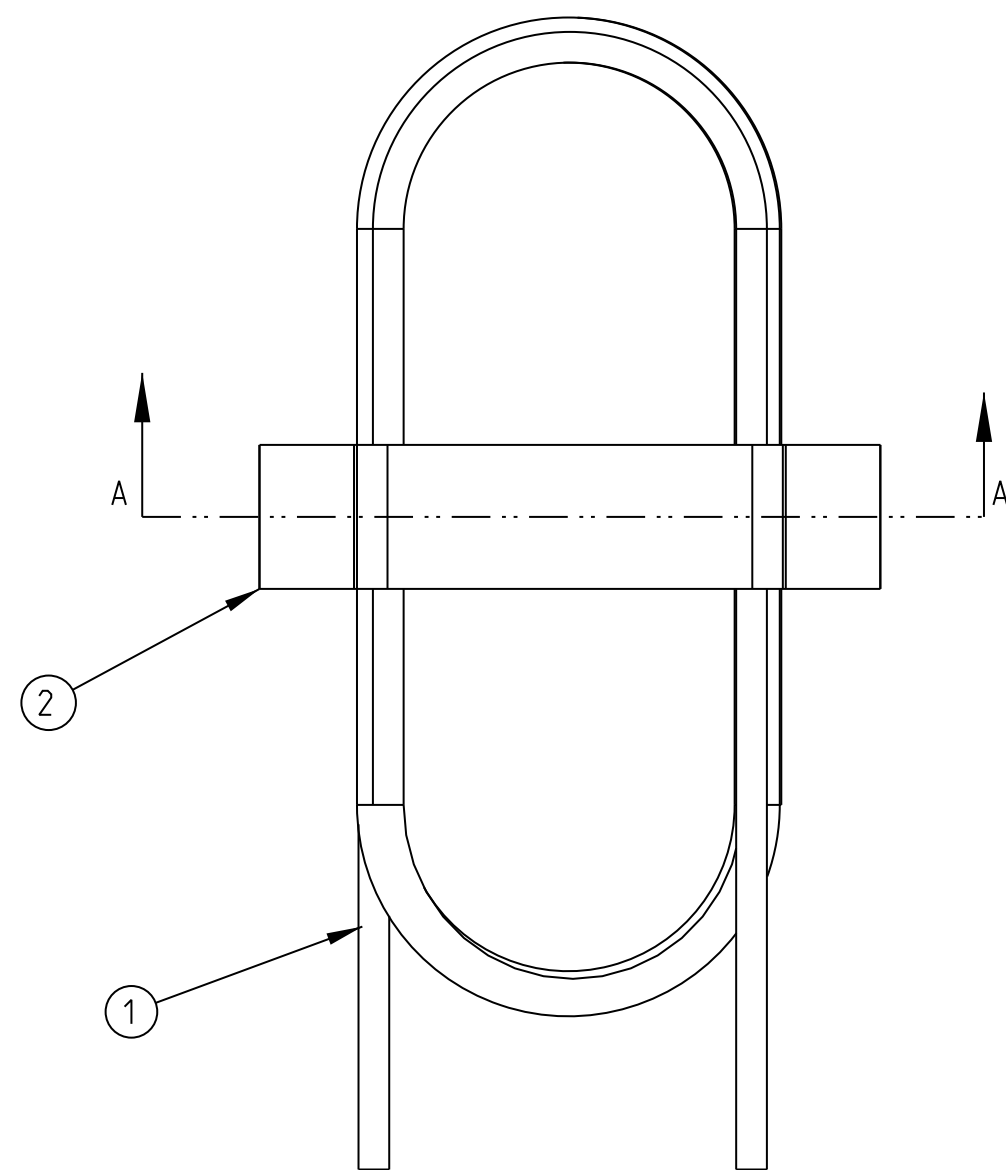
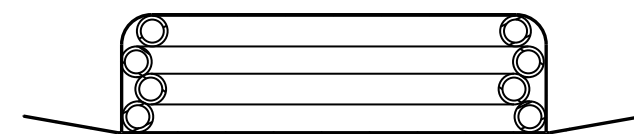

SECTION A-A

**NOTES:**

1. DIMENSIONS PER 212002841
2. ASSEMBLY P/N: 3014788

All technical information, equipment design and application data contained within this document is the CONFIDENTIAL property of MEDRAD, INC. No use or disclosure thereof may be made without written permission from MEDRAD, INC.

STANDARD SYMBOLGY	UNLESS OTHERWISE SPECIFIED
∅ DIAMETER	DIMENSIONS ARE IN INCHES
(XX) REF DIM	TOLERANCES ON:
L CBORE	2 PL DECIMALS ±.01
< CSK	3 PL DECIMALS ±.005
∇ DEPTH/DEEP	FRACTIONS 0"-6" ±1/32
XX DIM NOT TO SCALE	FRACTIONS 6"-UP ±1/16
	ANGULAR ±0° 30'
	MAX SURFACE TEXTURE 125√

**MEDRAD® INC.**  
ONE MEDRAD DRIVE  
INDIANOLA, PA 15051-0780

TITLE  
**SUB ASSEMBLY,  
TRANSFER SET  
CVTS**

MEDRAD 204813 REV C

SIZE	DWG NUMBER	REV
C	3015407	A
SCALE	1:1	SHEET 1 OF 2

▲ INSPECTION CHECKPOINT  
DO NOT SCALE DRAWING

