

Basics of Elasto-Plasticity in Creo Simulate – Theory and Application –



Presentation for the 4th SAXSIM
TU Chemnitz, Germany, 17.04.2012
Revision 2.1
Dr.-Ing. Roland Jakel

Table of Contents (1)

■ Part I – Theoretical Foundations

- Elasto-Plastic Material Basics (5-9)
- Elasto-Plastic Material Laws in Simulate (10-13)
- Defining Elasto-Plastic Material Laws – Curve Fitting (14-19)
- Multi-Axial Plasticity (20-24)
- Examination of Typical Stress States (25-35)
- Hardening Models (36-37)



■ Part II – Applying Simulate to Elasto-Plastic Problems

- Isotropic Hardening (39-40)
- Working with Material Laws in Simulate (41-42)
- Small Strain and Finite Strain Plasticity (43-45)
- Characteristic Measures in Plasticity (46-51)
- Load Stepping and Unloading (52-53)
- Meshing (54)



Table of Contents (2)

- **Part III – Application Examples**
 - A Uniaxial Test Specimen with Necking (56-64)
 - Flattening of a Tube End (65-67)
 - Forming of a Thin Membrane (68-70)

- **Part IV – Appendix**
 - Literature Sources (73-74)
 - Technical Dictionary English-German (75)



Acknowledgement

Many thanks to Tad Doxsee and Rich King from Christos Katsis' Simulation Products R&D, for the continuous support and all information

Part I

Theoretical Foundations

Basic Introduction into Elasto-Plasticity

The elasto-plastic stress-strain curve

- **True elastic limit (1):**
 - The lowest stress at which dislocations move
 - Has no practical importance
- **Proportionality limit (2):**
 - Limit until which the stress-strain curve is a straight line characterized by Young's modulus, E
- **Elastic limit, yield strength or yield point (3):**
 - Is the stress at which a material begins to deform plastically, means non-reversible (this is the lowest stress at which permanent deformation can be measured)
 - Before the yield point, the material deforms only elastically and will return to its original shape
- **Offset yield point or proof stress (4):**
 - Since the true yield strength often cannot be measured easily, the offset yield point is arbitrarily defined by using the stress value at which we have 0.1 or 0.2 % remaining strain. It is therefore described with an index, e.g. $R_{p0.2}$ for 0.2 % remaining strain like shown in the image

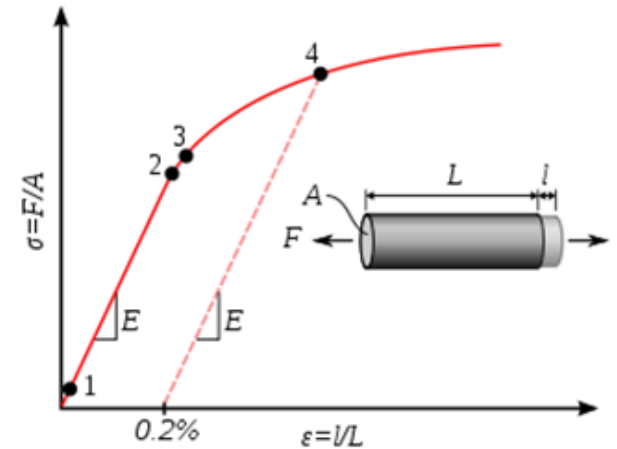

A typical stress-strain curve for non-ferrous alloys [1]

Engineering and true stress

- In stress-strain curves, usually the engineering stress $\sigma = F/A_0$ vs. engineering strain $\epsilon = \Delta l/l_0$ is shown
- If the material shows significant plastic behavior, the engineering stress σ decreases when the specimen shows necking
- The true stress $\sigma^* = F/A$ still increases, since there is a significant local reduction of area like shown in the right image
- In many practical applications (up to $\approx 5\%$ elongation), the difference is negligible

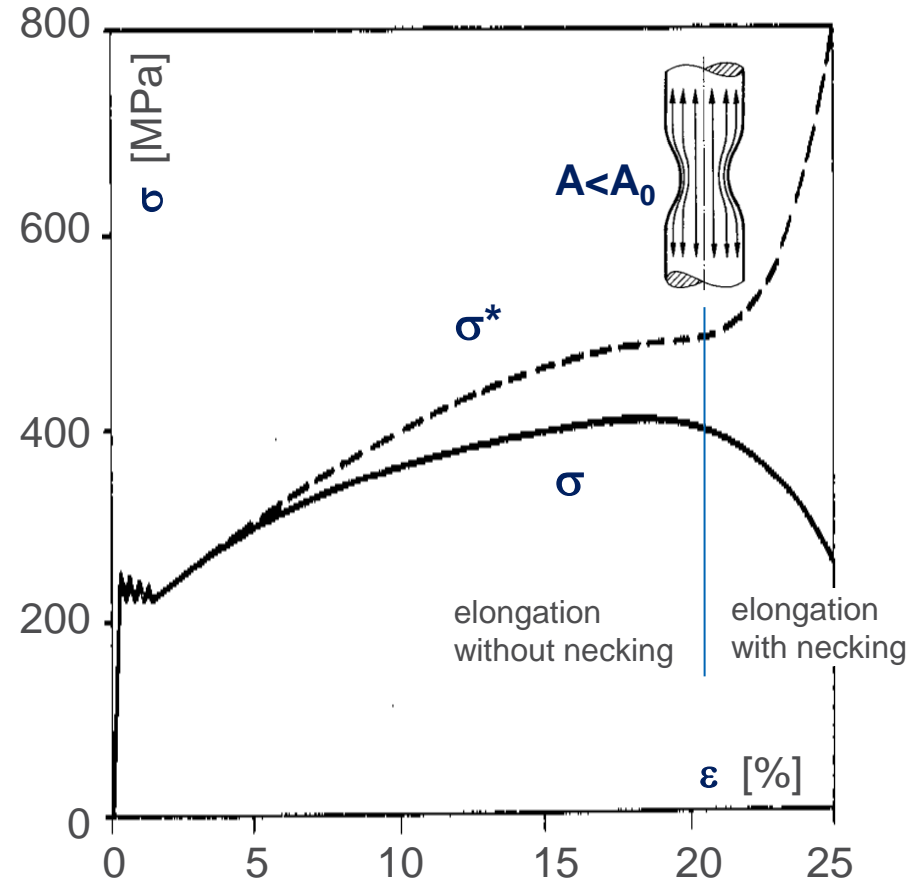

Stress-strain curve of a typical soft steel with engineering stress σ and true stress σ^* vs. engineering strain, modified from [3]

Fracture shapes in uniaxial specimens

- Brittle material (a) shows rupture in the plane of the maximum principal stress σ_1
- Ductile material (b) shows a crater-shaped shear fracture under 45° to the maximum principal stress plane near the specimen surface.
- Within the specimen, a brittle fracture shape can be observed, since inside the necked area we have a multiaxial stress state (c) with an acc. to [3] approximately equal axial, radial and tangential stress, which prevents yielding

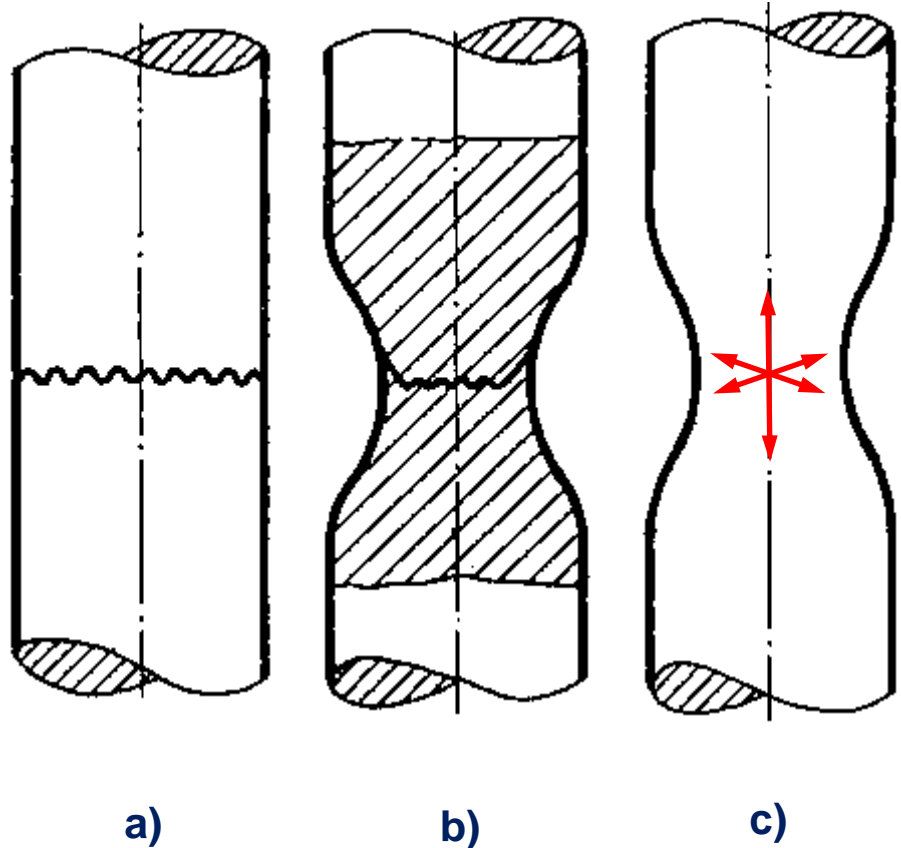

Fracture shapes and stress state in an uniaxial test specimen, modified from [3]

Typical uniaxial stress-strain curves [3]

- Hardened steel, e.g. for spring applications (1)
- Tempered steel (2)
- Soft steel (3)
- AlCuMg, hardened (4)
- Gray cast iron GG 18 (5)

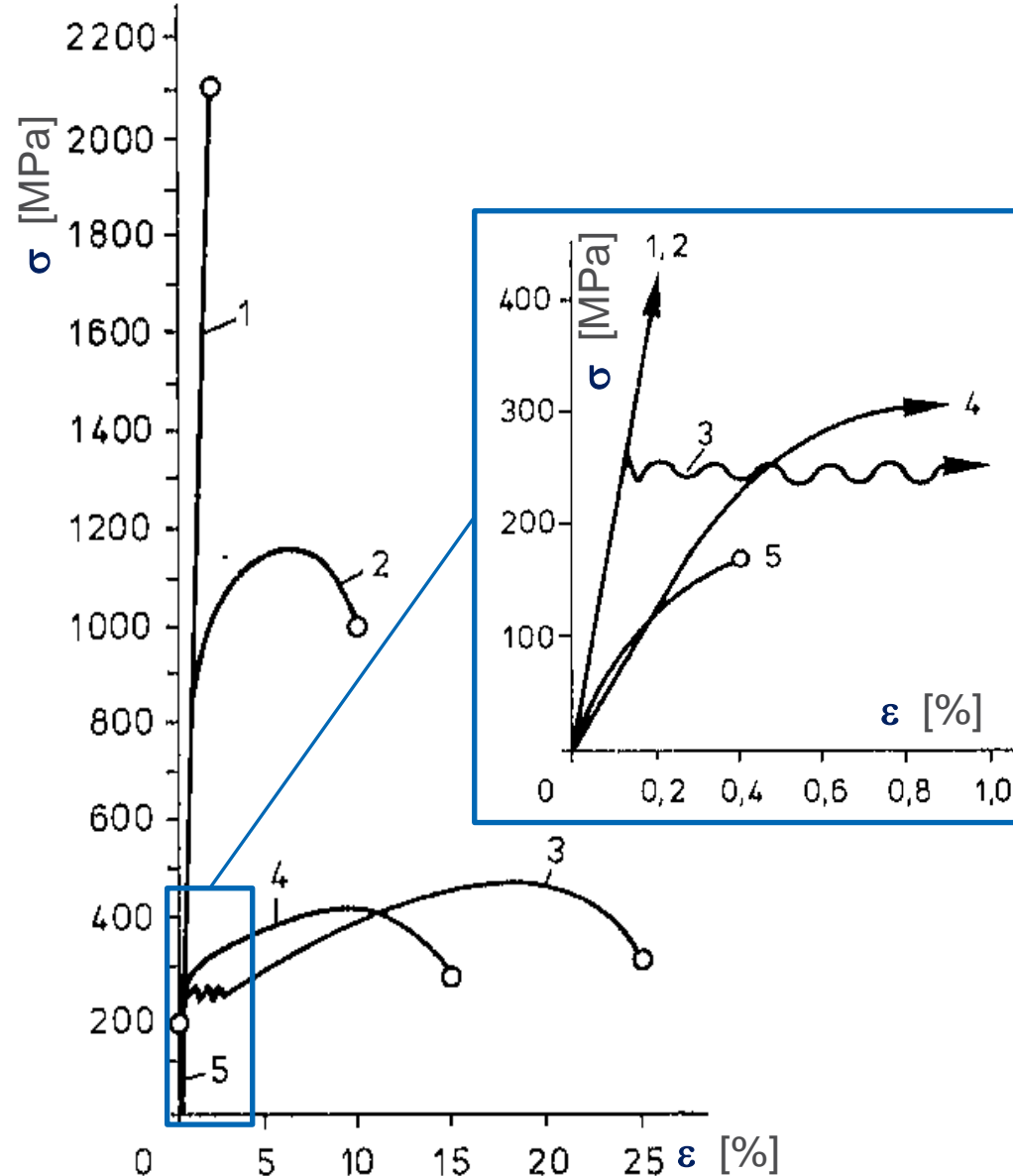

Shown is engineering stress versus engineering strain!

Comparison of elasto-plastic and hyperelastic material

■ Proportionality limit and elastic limit

- Note that for typical elasto-plastic material, there is often not a big difference between these two limits (points 2/3)
- In opposite, for elastomers, such as rubber which can be idealized as hyperelastic, there is a big difference between these points: These have an elastic limit much higher than the proportionality limit, and an elastic limit is not specially taken into account in the hyperelastic material formulation

■ Compressibility and Poisson effect

- Elastic strains in elasto-plastic materials usually appear with volume changes, the Poisson ratio is < 0.5 , e.g. 0.3
- In general, *plastic flow* of metals occurs without volume change. Mathematically, this means the Poisson ratio for plastic strains is 0.5 and $\varepsilon_{p_{xx}} + \varepsilon_{p_{yy}} + \varepsilon_{p_{zz}} = 0$
- In opposite to this behavior, hyperelastic material does not change its compressibility during loading, so as Wildfire 4 user you should never try to “approximate” any elasto-plastic material curve with the hyperelastic model!

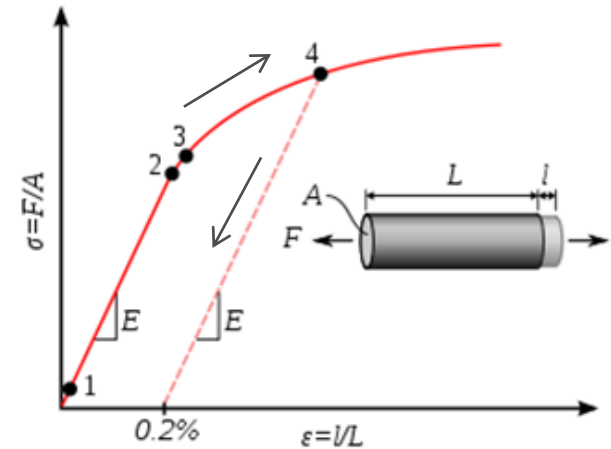

A typical stress-strain curve for non-ferrous alloys [1]

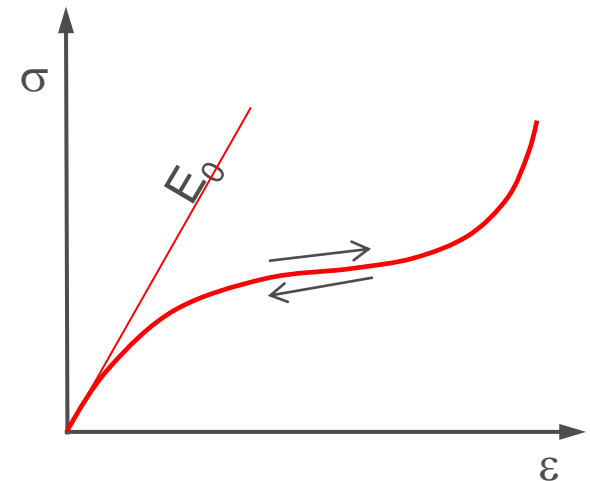

Hyperelastic material stress-strain curve [2]

Implemented Material Laws

- The material laws are a one dimensional relation of stress versus plastic strain
- Creo Simulate supports four material laws for describing plasticity:
 - elastic – perfectly plastic: Above the yield limit the stress ($\sigma_y = \sigma_{\text{yield}}$ = yield stress) is constant independently of the plastic strain reached (a special case of the linear hardening model with $E_m = 0$)
 - „Linear hardening“: The relation between stress and plastic strain is constant („tangent modulus“ E_m with slope $0 < E_m < E$)
 - Power (Potential) law: $0 < E_m < E$, $0 < m \leq 1$
 - Exponential law: $m > 0$, $\sigma_{\text{limit}} > 0$

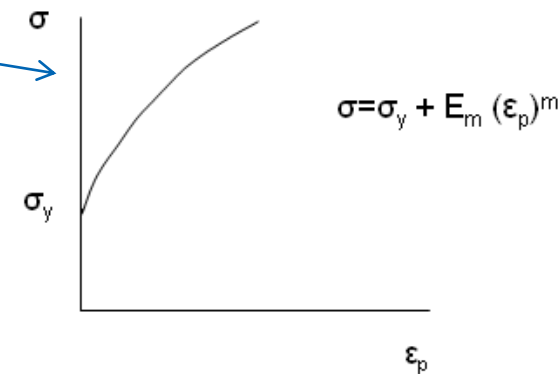
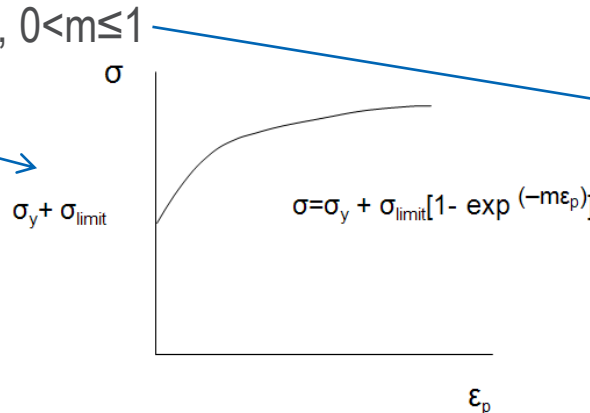
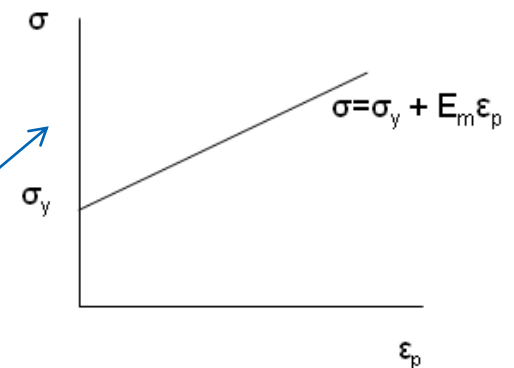
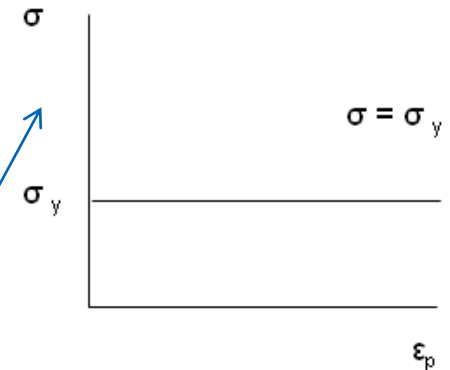

Coefficient of thermal softening – CTS (1)

- This coefficient takes into account that the yield strength of a material falls with increasing temperature. It is regarded as a constant material parameter and allows to take into account temperature influence when analyzing plasticity. It is valid for all plasticity models supported.

- The coefficient of thermal softening β is defined in Simulate as follows:

$$Y_1 = Y_0 \cdot (1 - \beta \Delta T) = Y_0 \cdot (1 - \beta(T_1 - T_0))$$

- Herein, Y_0 is the material yield strength entered in the material definition dialogue (Simulate assumes this is for the reference temperature T_0), and β (dimension 1/temperature) is the coefficient of thermal softening. Y_1 is the yield strength at the model temperature T_1 .
- Note: In order to prevent a negative yield stress, the condition $\beta^*(T_1 - T_0) < 1$ must be fulfilled! The engine issues an error and stops if this appears.

Coefficient of thermal softening (2)

- In [6], there is a more general formulation of the thermal softening, which is based on the power (potential) plasticity law and also takes into account the strain rate (loading speed):

$$\sigma = \left\{ A + B \varepsilon^n \right\} \left\{ 1 + C \ln \dot{\varepsilon}^* \right\} \left\{ 1 - T^{*m} \right\}$$

$$T^* = \left(\frac{T - T_{Room}}{T_{Melt} - T_{Room}} \right)$$

- Herein, we have 5 material parameters A, B, n, C, m.

- $\dot{\varepsilon}^* = \dot{\varepsilon} / \dot{\varepsilon}_0$ is the dimensionless plastic strain rate for $\dot{\varepsilon}_0 = 1.0s^{-1}$ [6].
 T^* is the homologous temperature, and σ the von Mises flow stress.

Expressed in formula letters more common in this presentation, we obtain

$$Y_1 = \left\{ \sigma_y + E_m (\varepsilon_0)^m \right\} \left\{ 1 + C \ln \frac{\dot{\varepsilon}_1}{\dot{\varepsilon}_0} \right\} \left\{ 1 - \left(\frac{T_1 - T_0}{T_{Melt} - T_0} \right)^{\beta^*} \right\}$$

- So, the CTS used in Simulate is a linearization of the temperature function given above, which is good for most cases. The strain rate has to be taken into account directly by modifying the material law parameters, if required.

$$Y_1 = Y_0 \cdot (1 - \beta \Delta T) = Y_0 \cdot (1 - \beta (T_1 - T_0))$$

Coefficient of thermal softening (3)

- The influence of thermal softening is depicted in [6] for various materials

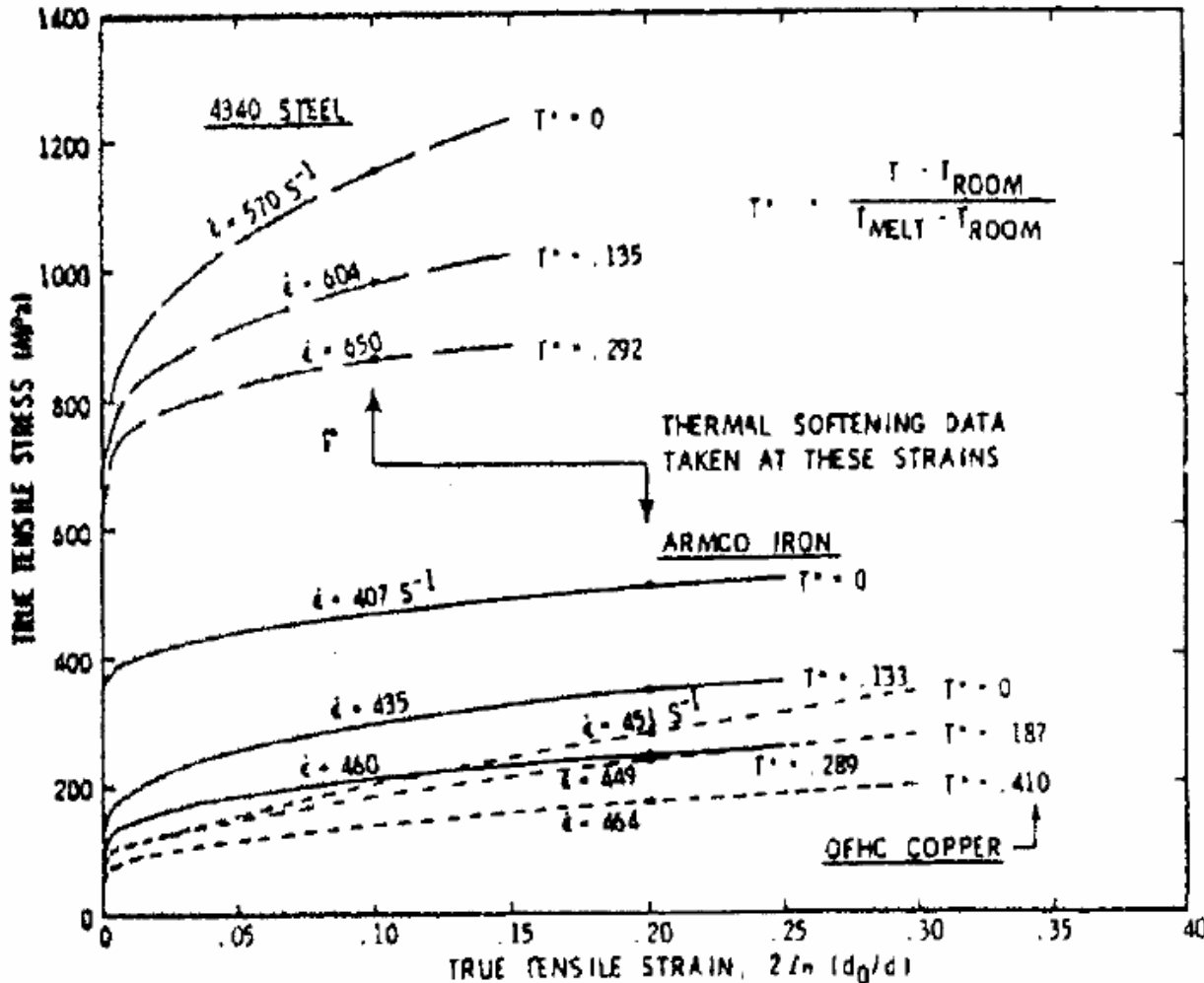

Stress-strain curves for materials beyond the elastic limit can be defined by tests

- Simulate can automatically select the material law from linear least squared best-fit, if the user enters uniaxial tension test data
- Manual selection/input is possible, too

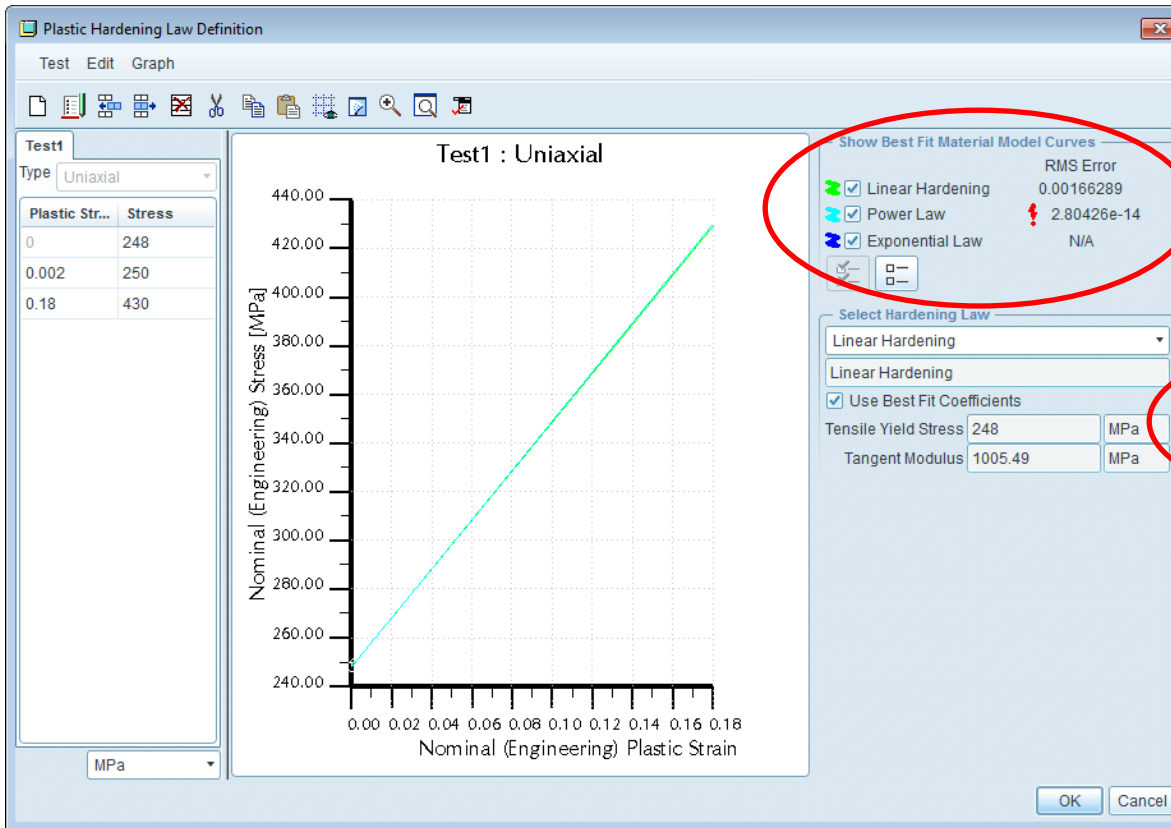

Isotropic hardening laws using linear least squared fitting algorithm [4]

- The following slides show what happens behind the Simulate user dialogue when material test data is input

- If we have an equation

$$y = a + bx$$

then the coefficients a and b can be evaluated from the following equations:

$$a = \frac{\sum y_i \cdot \sum x_i^2 - \sum x_i \cdot \sum x_i y_i}{n \sum x_i^2 - (\sum x_i)^2}$$

$$b = \frac{n \sum x_i \cdot y_i - \sum x_i \cdot \sum y_i}{n \sum x_i^2 - (\sum x_i)^2}$$

- Here, n is the number of data points, (x_i, y_i) is the data pair and the summation goes from 1 to n

Application of linear least squared fitting algorithm to isotropic hardening laws [4]

- Linear plasticity

$$\sigma = \sigma_y + E_m \varepsilon_p$$

or: $Y = A + BX$

$$Y - A = BX$$

Here: $y = Y - A$

$$a = 0$$

$$b = B$$

$$x = X$$

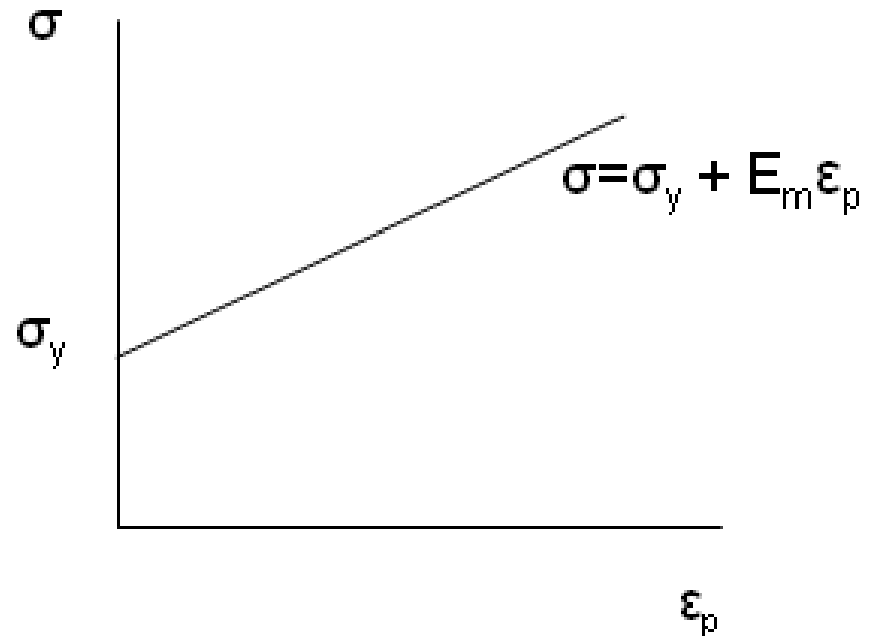

Application of linear least squared fitting algorithm to isotropic hardening laws (cont'd)

- Power (potential) plasticity law

$$\sigma = \sigma_y + E_m (\varepsilon_p)^m$$

or: $Y = A + BX^m$

Taking logs on either side to the base e:

$$\log_e (Y - A) = \log_e B + m \log_e X$$

Here: $y = \log_e (Y - A)$

$$a = \log_e B$$

$$b = m$$

$$x = \log_e X$$

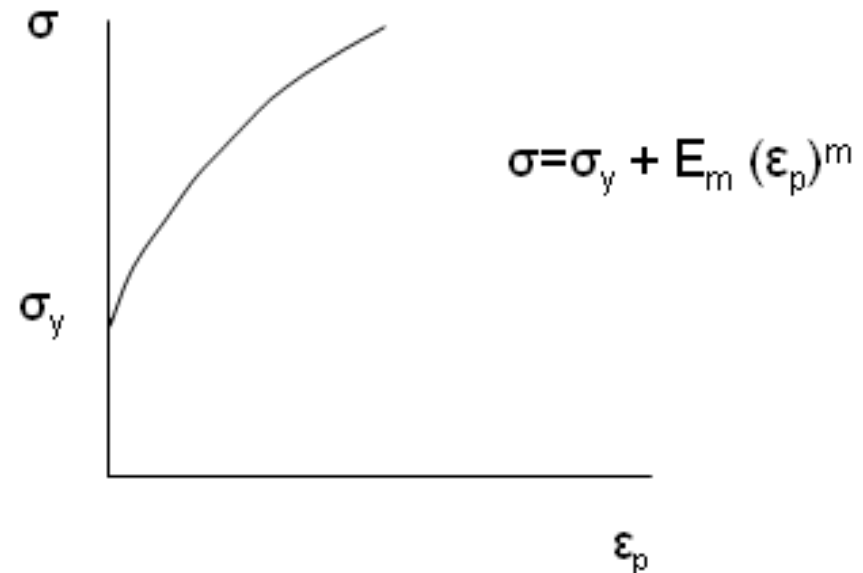

Application of linear least squared fitting algorithm to isotropic hardening laws (cont'd)

- Exponential plasticity law

$$\sigma = \sigma_y + \sigma_{\text{lim}} (1 - \exp(-m\varepsilon_p))$$

or: $Y = A + B(1 - \exp(-mX))$

$$Y - A = B - Be^{-mX}$$

Taking derivatives on either side, with respect to X:

$$\frac{d(Y - A)}{dX} = mBe^{-mX}$$

Taking logs on either side to the base e:

$$\log_e \frac{d(Y - A)}{dX} = \log_e (mB) - mX$$

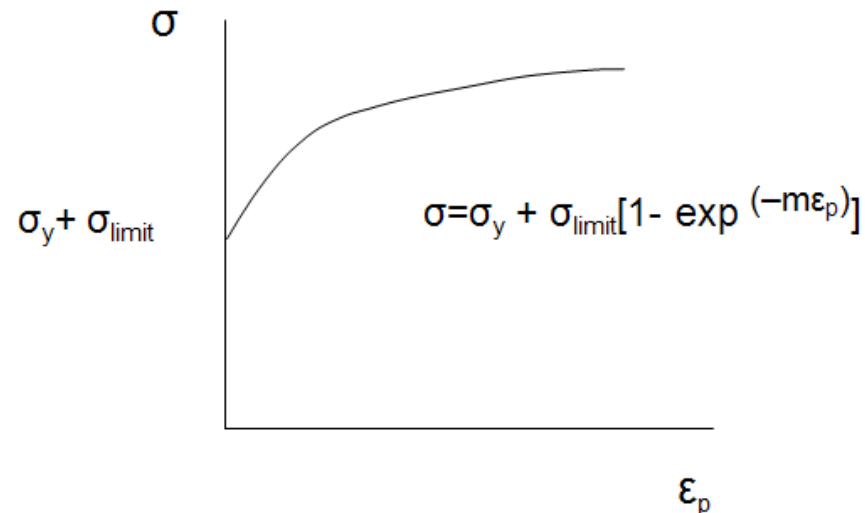

Application of linear least squared fitting algorithm to isotropic hardening laws (cont'd)

- Then, we obtain:

$$y = \log_e \left(\frac{d(Y - A)}{dX} \right)$$

$$a = \log_e (mB)$$

$$b = -m$$

$$x = X$$

After evaluating m (from b),
we can evaluate B (from a)

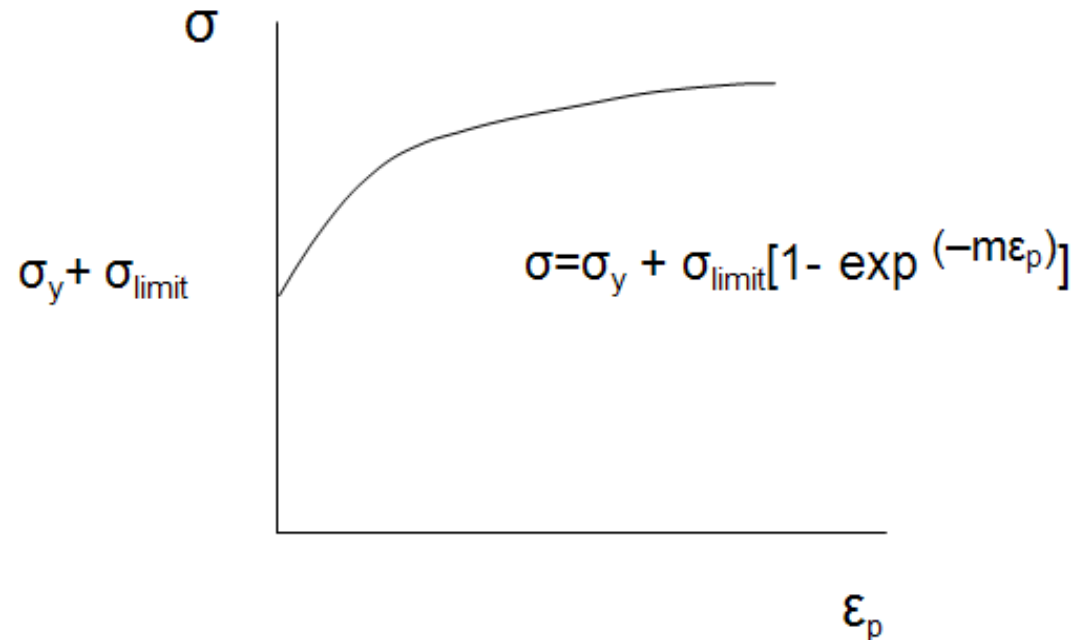

Yield point and yield surfaces

- The material laws are a one dimensional relation of stress versus plastic strain. Only uniaxially tension loaded specimens are used for characterizing the elasto-plastic material behavior, where we have one yield point only.
- In the three-dimensional space of the principal stresses ($\sigma_1, \sigma_2, \sigma_3$), an infinite number of yield points form together the yield surface.
- In real structures, we usually have biaxial stress states at the surface and – more or less – three-axial stress states within the structure. Hence, we need a suitable criteria to form an equivalent uniaxial, scalar comparative stress, called the yielding condition or yield criteria.
- In literature, several different yield criteria can be found for isotropic materials.
- The subsequent slide shows only the most popular criteria for yielding of isotropic, ductile materials.

Classical isotropic yield criteria

■ Maximum Shear Stress Theory (Tresca yield criterion)

- Yield in ductile materials is usually caused by the slippage of crystal planes along the maximum shear stress surface.
- The French scientist Henri Tresca assumed that yield occurs when the shear stress exceeds the uniaxial shear yield strength τ_{ys} :

$$\tau_{\max} = \frac{\sigma_1 - \sigma_3}{2} \leq \tau_{ys}$$

■ Distortion Energy Theory (von Mises yield criterion)

- This theory proposes that the total strain energy can be separated into two components: the volumetric (hydrostatic) strain energy and the shape (distortion or shear) strain energy. It is assumed that yield occurs when the distortion component exceeds that at the yield point for a simple tensile test. The hydrostatic strain energy is ignored.

$$\frac{1}{2} [(\sigma_1 - \sigma_2)^2 + (\sigma_2 - \sigma_3)^2 + (\sigma_3 - \sigma_1)^2] = \sigma_y^2$$

- Based on a different theoretical derivation it is also referred to as “octahedral shear stress theory”
- Simulate supports this yield criteria only, since it is most commonly used and often fits with experimental data of very ductile material

Graphical representation of classical criteria

- In the three-dimensional space of the principal stresses ($\sigma_1, \sigma_2, \sigma_3$), an infinite number of yield points form together the yield surface. If the stress state is within this surface, no yielding appears.

- The most popular criteria, Tresca and von Mises,

$$\tau_{\max} = \frac{\sigma_1 - \sigma_3}{2} \leq \tau_{ys}$$

$$\frac{1}{2} [(\sigma_1 - \sigma_2)^2 + (\sigma_2 - \sigma_3)^2 + (\sigma_3 - \sigma_1)^2] = \sigma_y^2$$

look like shown right

- The von Mises yield surface is therefore called the “yield cylinder”

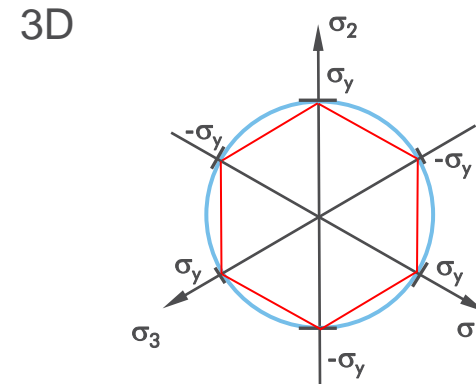
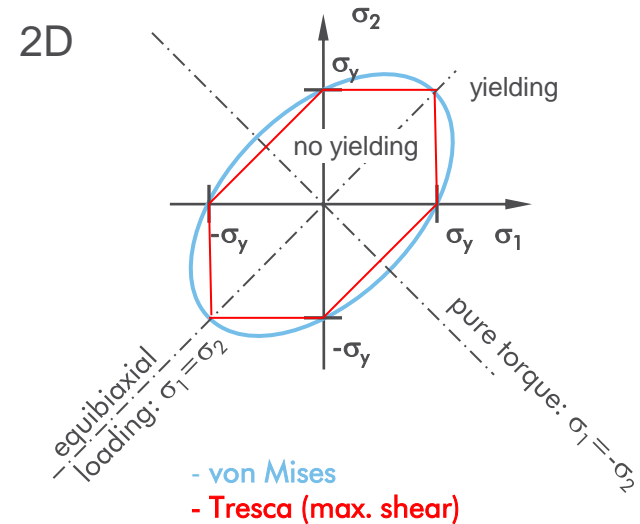

Yield criteria for plane stress ($\sigma_3=0$, top) and any three-axial stress state (bottom)

Other Isotropic yield criteria

■ Generalized Isotropic Yield Criterion (Hosford)

$$\left[\frac{(\sigma_1 - \sigma_2)^n + (\sigma_2 - \sigma_3)^n + (\sigma_3 - \sigma_1)^n}{2} \right]^{1/n} = \sigma_y$$

- Experimental and theoretical data on yielding under combined stresses can be described by a single parameter, n , with $1 \leq n \leq \infty$
- For $n=2$, this equals the von Mises criterion
- This criterion was proposed in 1972 by W. F. Hosford, Department of Materials and Metallurgical Engineering, The University of Michigan, Ann Arbor, Mich [7]

■ More criteria and deeper information can be found e.g. in [8] and [9]

Graphical representation of some other isotropic yield criteria

- Comparison of different popular criteria [9]

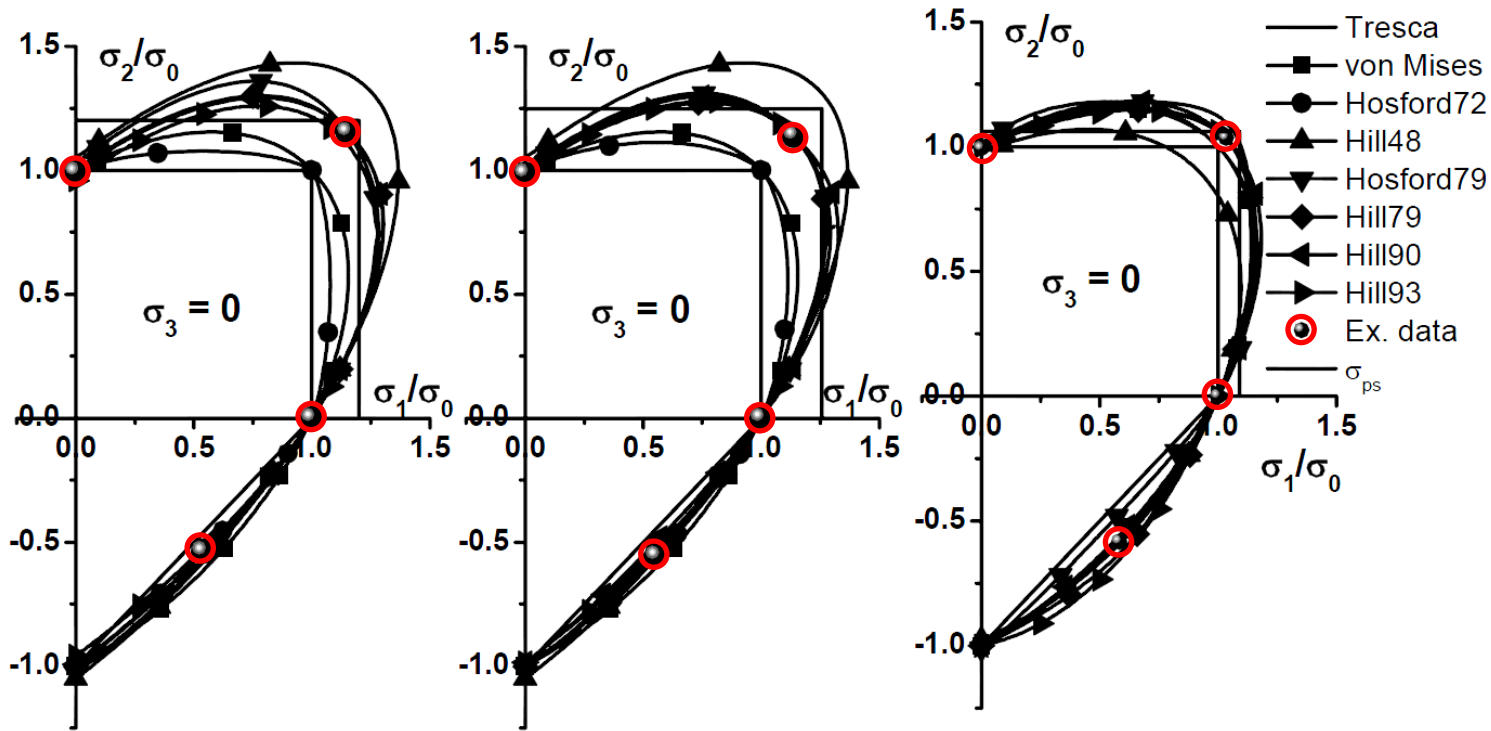

(a)

(b)

(c)

- a. IF-steel
- b. LC-steel
- c. Aluminum alloy

Von Mises Stress and Principal Stresses

- Note the von Mises yielding condition must always be satisfied:

$$2\sigma_{yield}^2 = (\sigma_1 - \sigma_2)^2 + (\sigma_2 - \sigma_3)^2 + (\sigma_3 - \sigma_1)^2$$

- This has some consequences, e.g.:
 - In a uniaxial stress state, the yield stress and the maximum principal stress will always be the same – the maximum principal stress can never be greater than the von Mises stress!
 - In a biaxial stress state, it may happen that one or more principal stresses may well be above or below the uniaxial yield stress, so do not be surprised!
 - In equi-triaxial tension, yielding will never appear, since the principal stress differences are zero. The material will break if the principal stress reaches ultimate stress, while the von Mises stress will still be zero. A ductile material will behave brittle in this case, that means rupture appears suddenly without previous yielding!
- In the following slides, we will examine some characteristic stress states with a small demonstration model for better understanding

Demonstration model

- We use a unit volume with symmetry constraints
 - Loads can be applied with forces or enforced displacements in all principal directions
 - The mesh consists of one p-brick only
 - We have created measures for stress (true and engineering) and strain (log and engineering), equivalent plastic strain, reaction forces and absolute volume
- Note:
 - Simulate uses exactly $\nu=0.5$ for plastic (incompressible) strains, not 0.4995 like for incompressible hyperelastic material
 - In hyperelasticity, 0.5 can lead to “dilatational locking”, where the mesh acts too stiff for numerical reasons, and 0.4995 fixes that. This problem does not occur in plasticity.

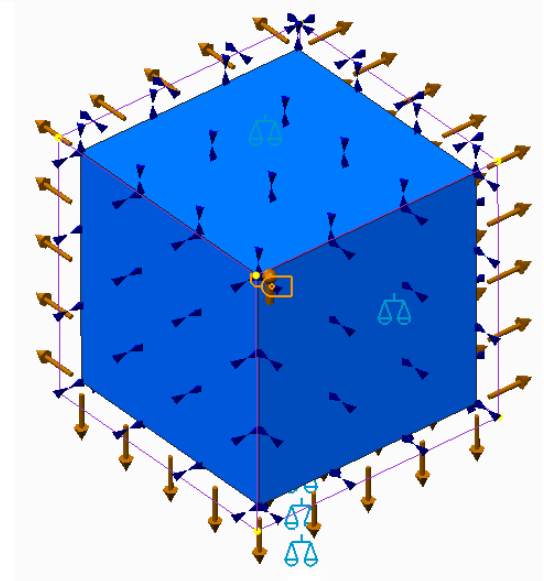
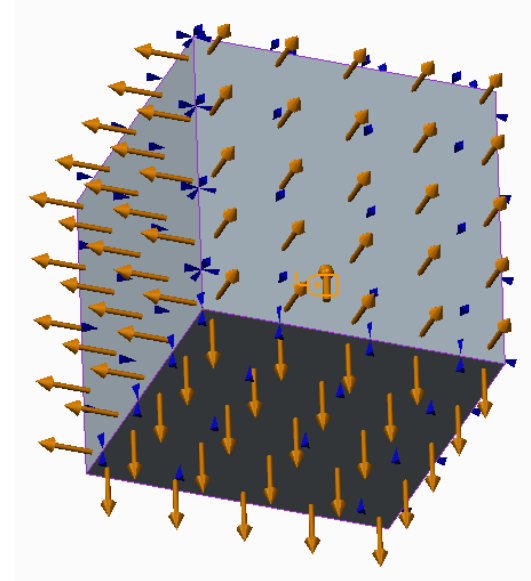

Material model used

- Simple linear hardening and perfect plasticity model used

- Very soft model steel with
 - $E=200000$ MPa
 - Yield strength = 100 MPa
 - Elastic Poisson ratio = 0.3
 - Tangent modulus (linear hardening only) = 2000 MPa
- At its yield strength, the strain should be

$$\varepsilon_1 = \frac{1}{E} \sigma_1 = 0.0005 = 0.05\%$$

- The lateral strains are:

$$\varepsilon_2 = \varepsilon_3 = -\frac{\nu}{E} \sigma_1 = -0.00015 = -0.015\%$$

- At the yield strength, the unit volume of $V_0=1 \text{ mm}^3$ increases to

$$V_1 = (1 + \varepsilon_1)(1 + \varepsilon_2)(1 + \varepsilon_3) \approx 1.0002 \text{ mm}^3$$

- All subsequent analyses performed in LDA

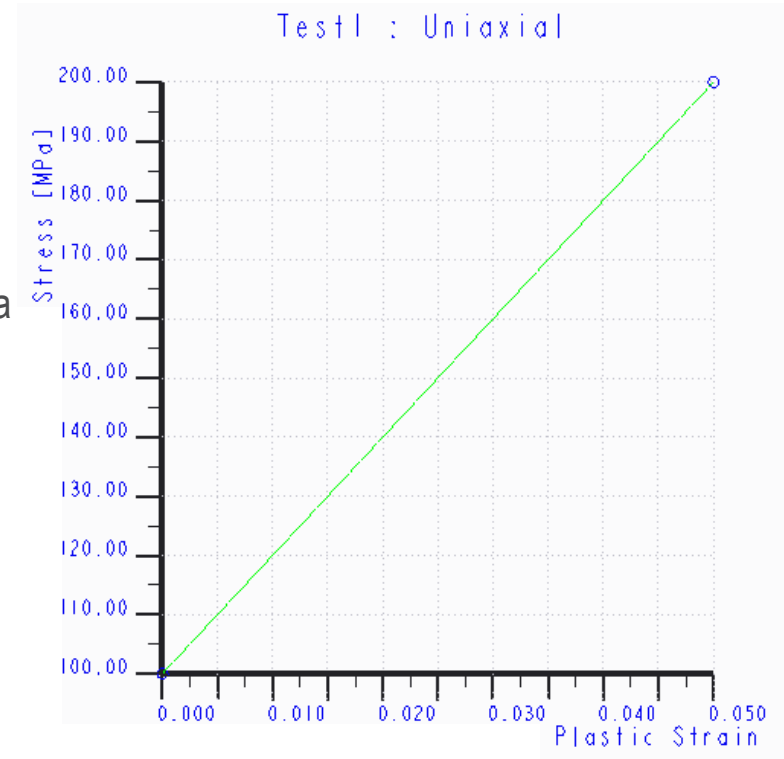

Note:

Log strain LDA results are translated into engineering strains with computed measures, e.g. $(e^{\text{strain_XX}})-1$

Uniaxial Tension

- Perfect plasticity results

- Axial stress stays constant at 100 MPa after yielding
- Volume does not further increase when material yields, like expected

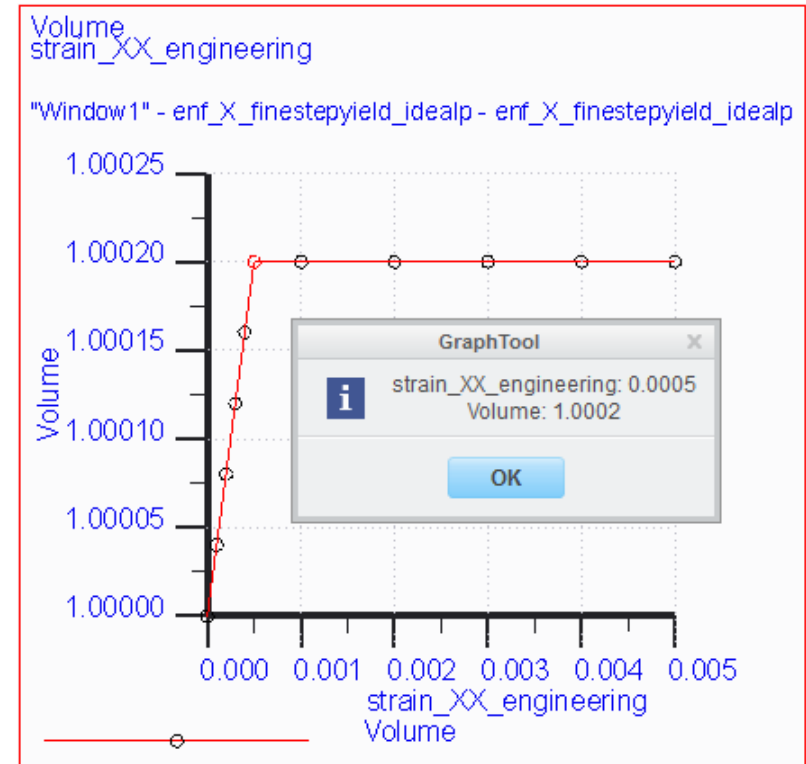
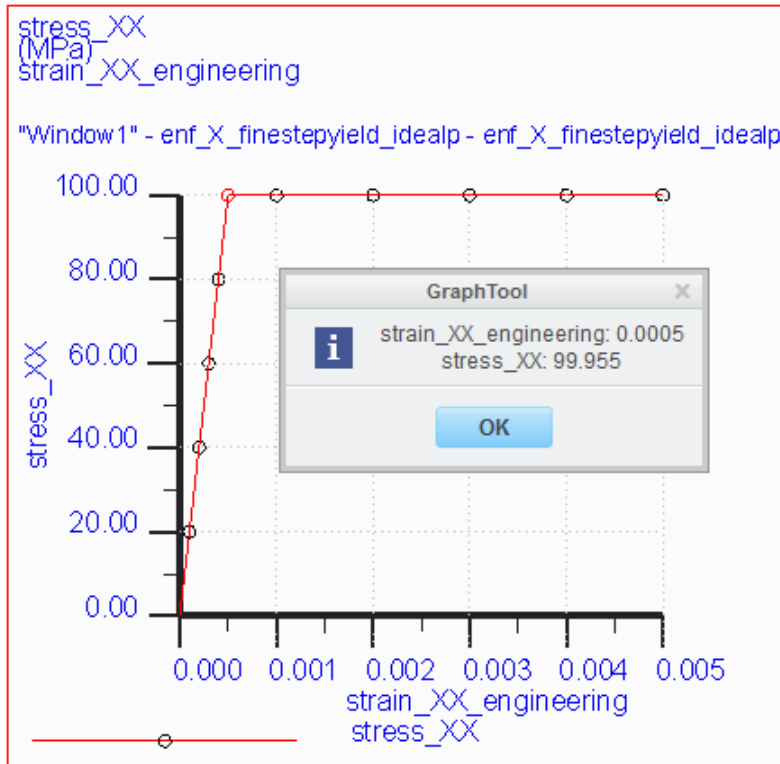
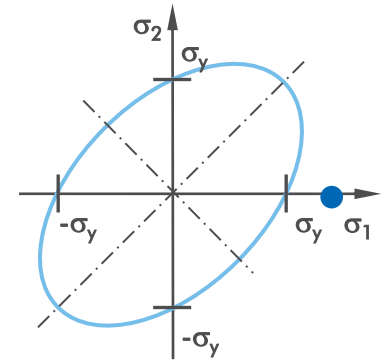

Uniaxial Tension

Linear hardening results

- Axial stress = 1st principal stress increases with factor 100 reduced slope after yielding
- Volume further increases when material yields: Elastic strain increases because stress increases during yielding, too! (Note: Analysis was performed in LDA, since SDA cannot capture this volume change very accurately)

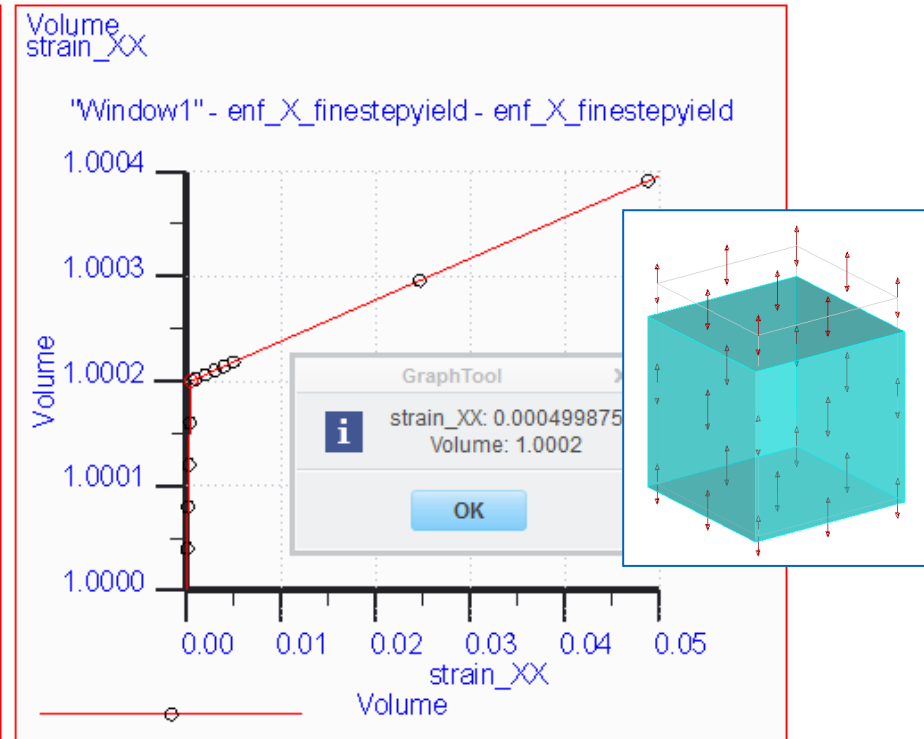
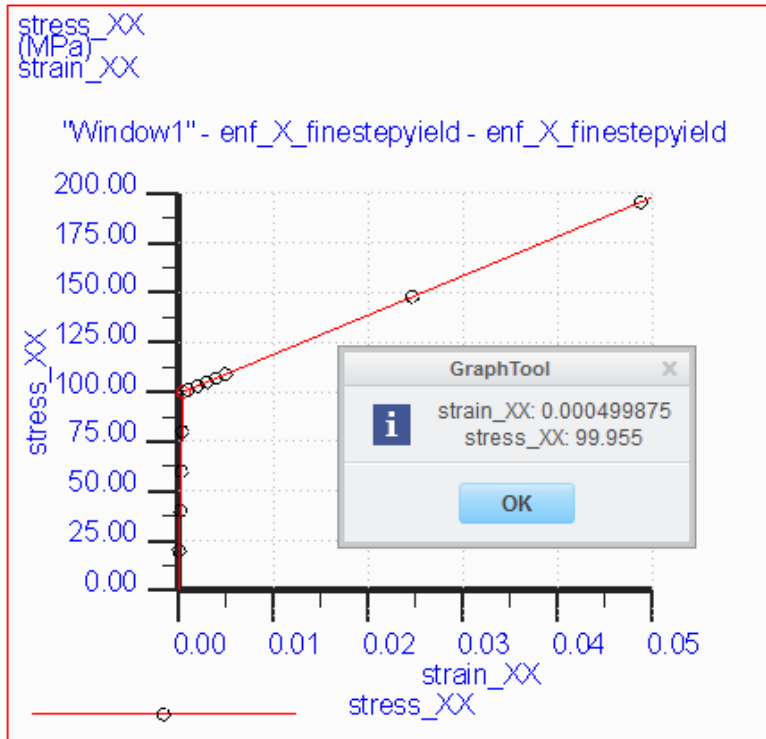

Pure Torque (1)

- We load the volume with the uniaxial yield limit strength: $\sigma_x = -\sigma_y = Y_0$
 - Von Mises stress vs. equivalent plastic strain reflects the uniaxial linear hardening material input curve, like expected

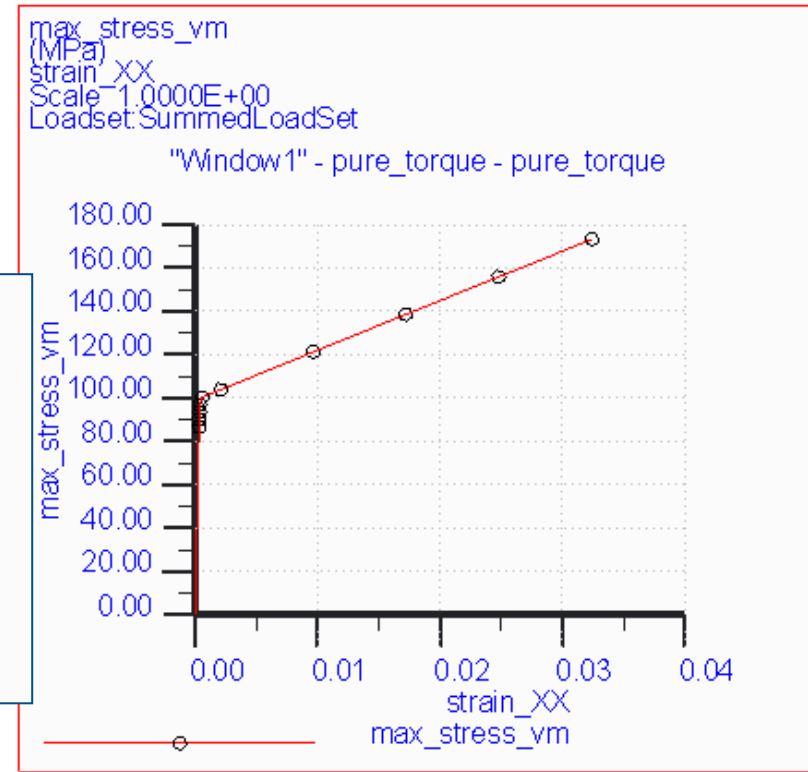
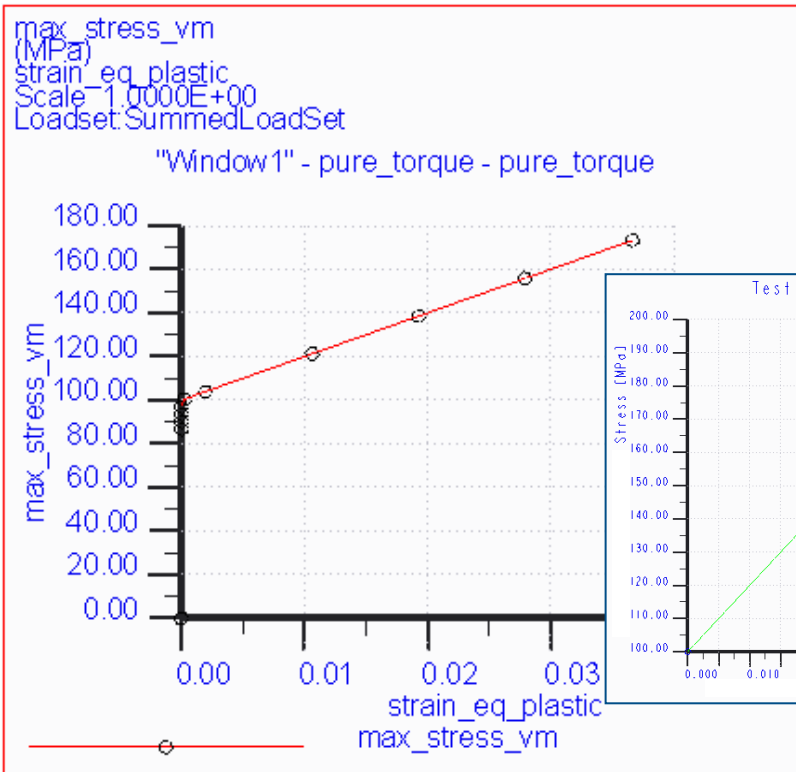
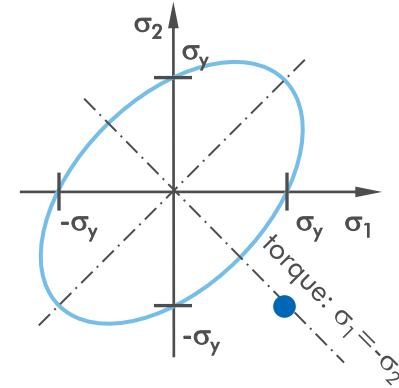

Pure Torque (2)

- The max. and min. principal stresses (= x and y-stress) show yielding much below the uniaxial yield strength of 100 MPa!

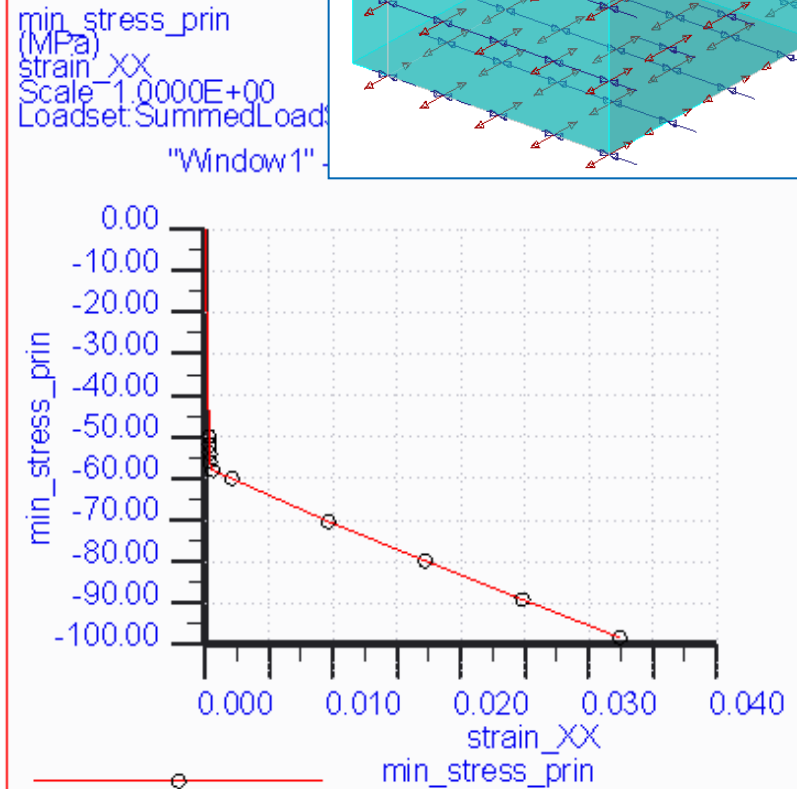
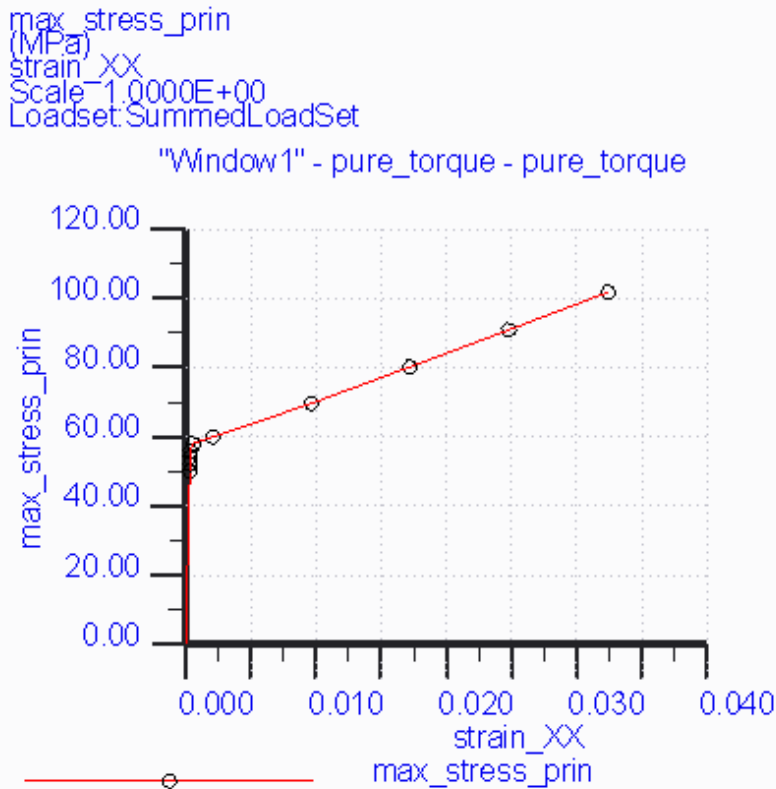
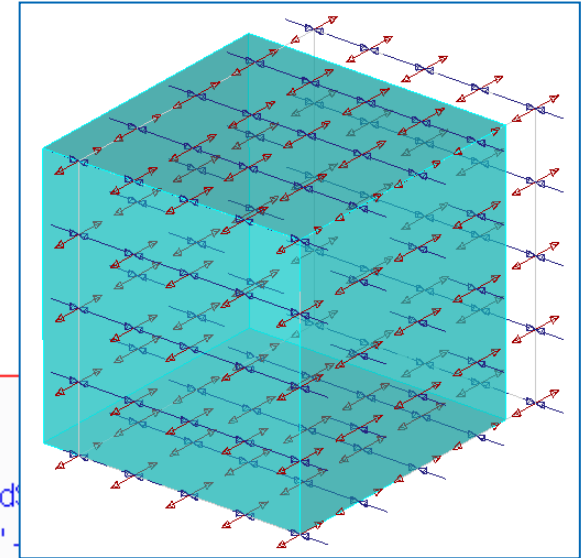

Pure Torque (3)

- The volume should not change for this loading state, just small numerical disturbances
- Strain energy increases dramatically after von Mises stress reaches yield limit of 100 MPa

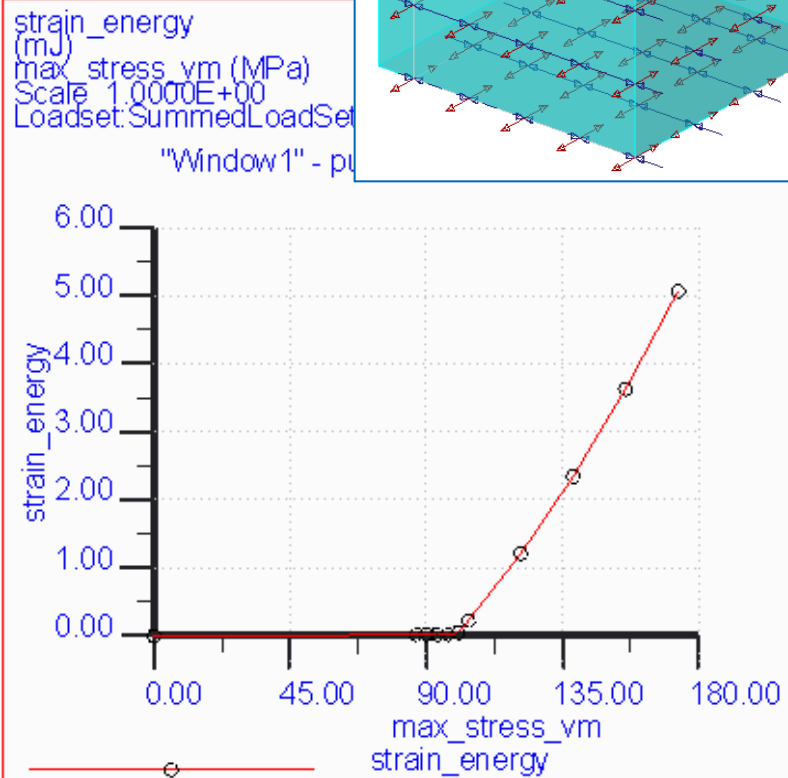
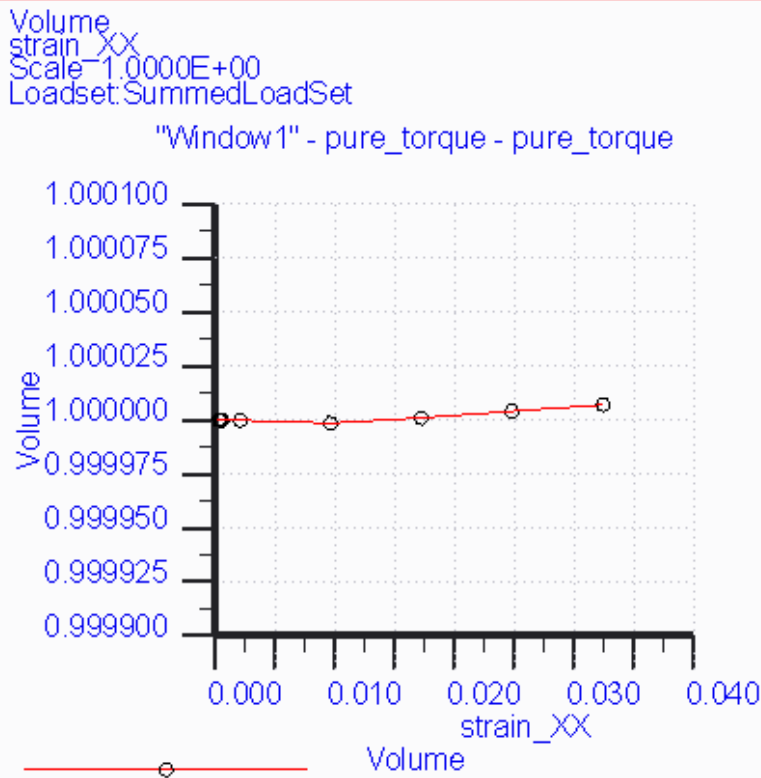
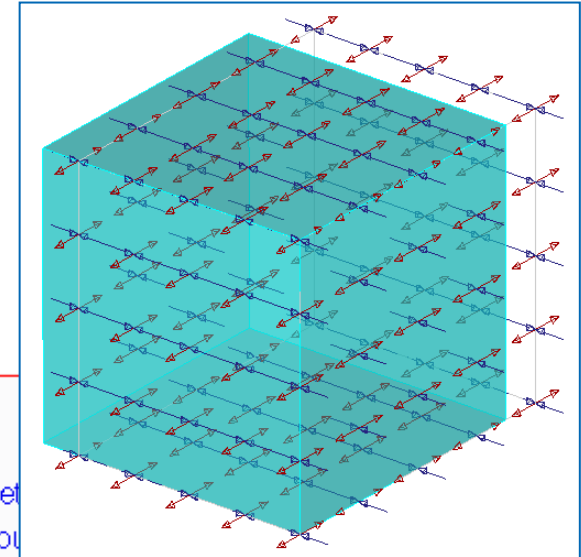

Biaxial tension ratio: $\sigma_1 = 1.2 Y_0$; $\sigma_2 = 0.5 Y_0$; $\sigma_3 = 0$

- This biaxial, plane stress state allows to load the material well above the uniaxial yield limit without yielding!
- Just above $\sigma_1 = \sigma_x = 115$ MPa yielding takes place, 15 % above the uniaxial limit

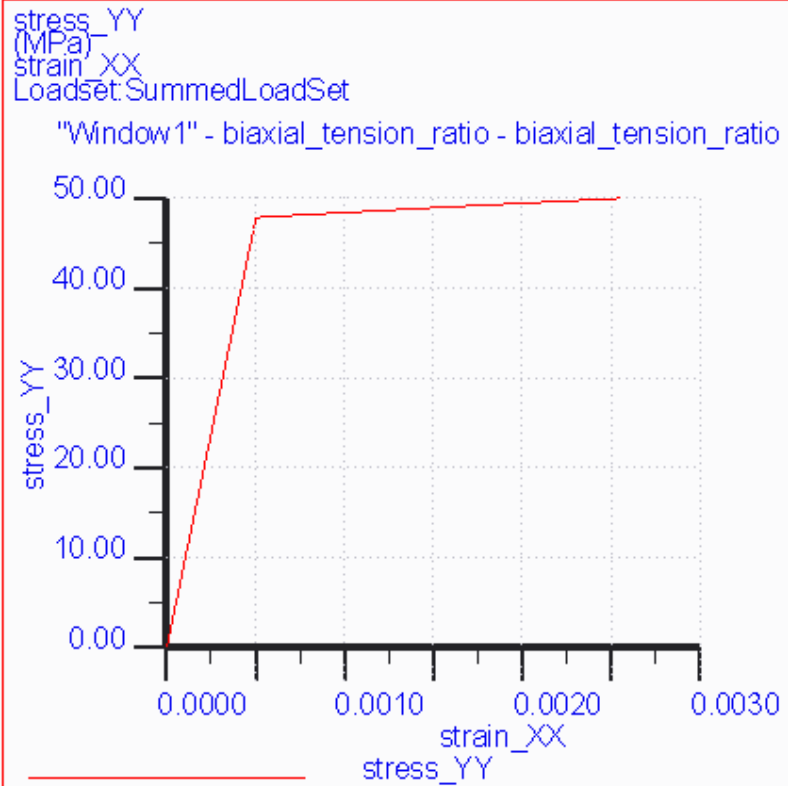
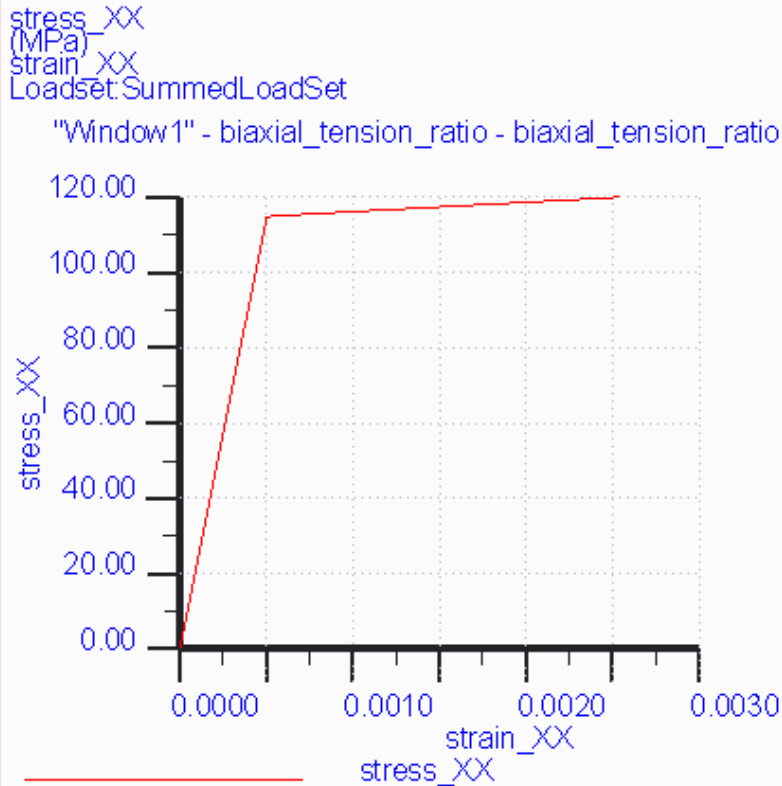
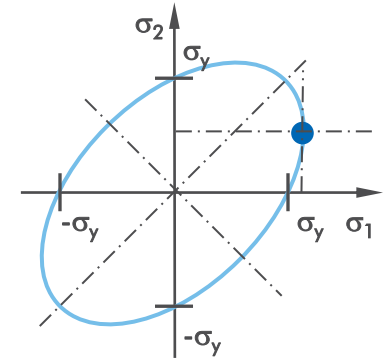

Biaxial tension ratio: $\sigma_1 = 1.2 Y_0$; $\sigma_2 = 0.5 Y_0$; $\sigma_3 = 0$

- The graph Y-Stress vs. Y-strain shows a sharp bend, since negative incompressible Y-strain prevails after yielding!
- The von Mises stress vs. X-strain shows the uniaxial material behavior, like expected

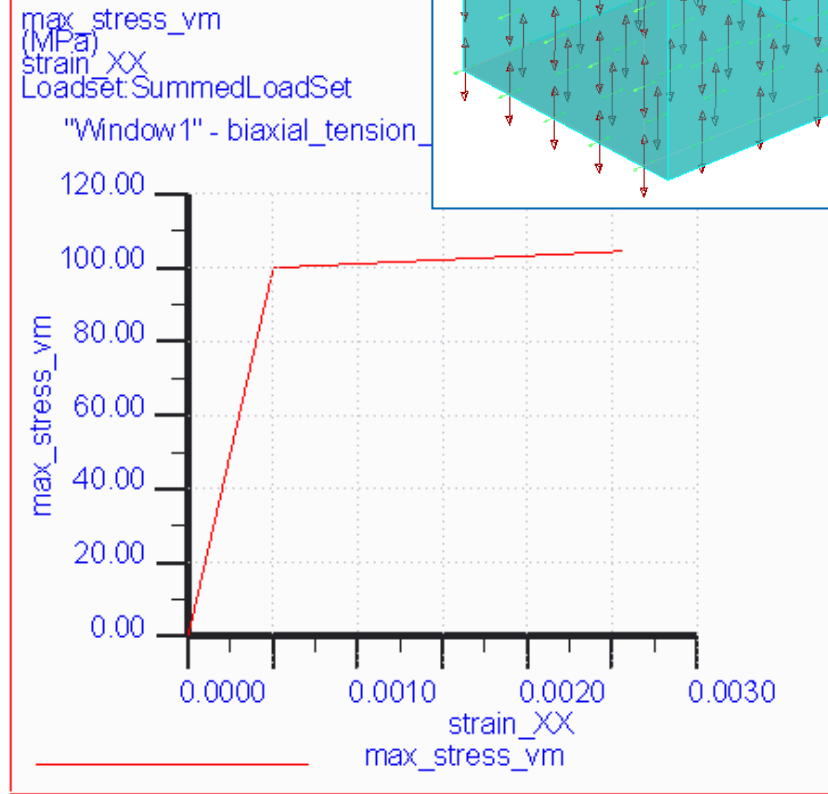
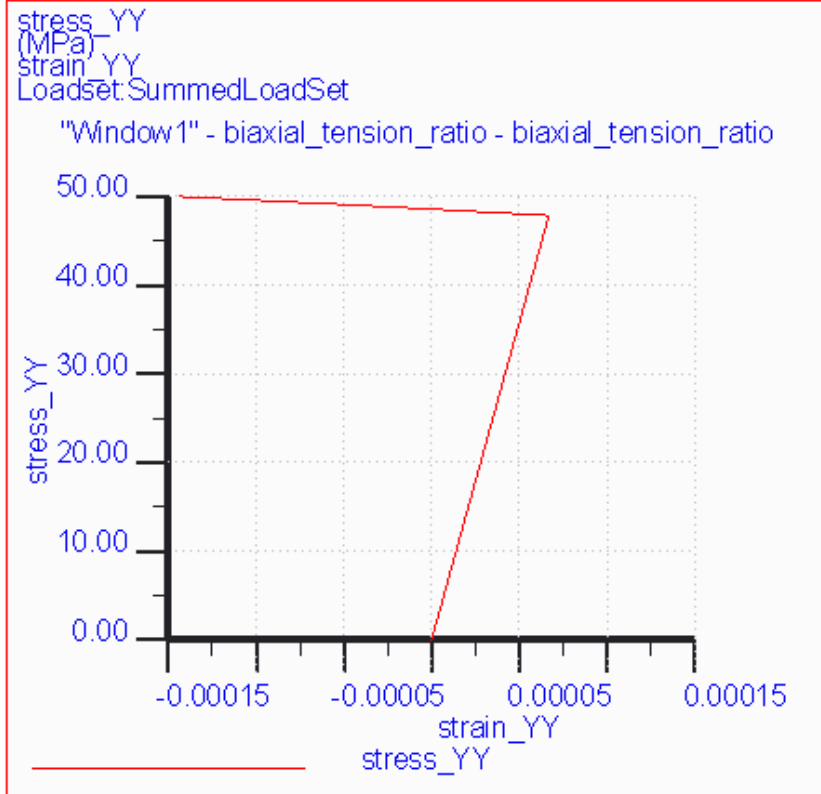
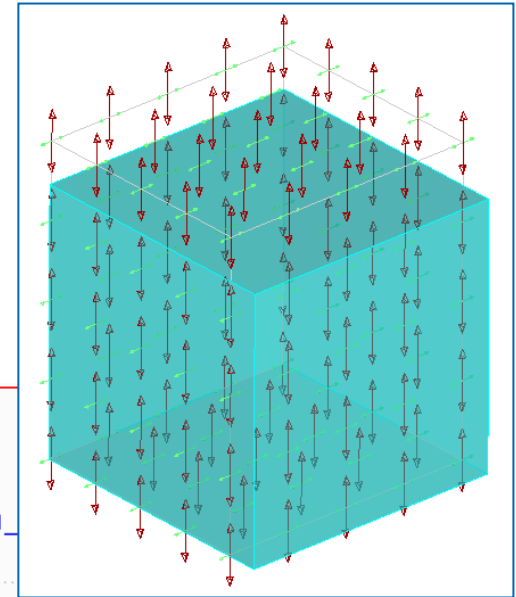

Equitriaxial tension

- We load all directions, e.g. $\sigma_x = \sigma_y = \sigma_z = 10Y_0$
 - Yielding never appears, since all principal stress differences are zero
 - In equitriaxial tension, the ductile material will suddenly break brittle when ultimate strength is reached, without previous yielding
 - Under hydrostatic pressure, yielding or even rupture in general will not appear under practical achievable pressures

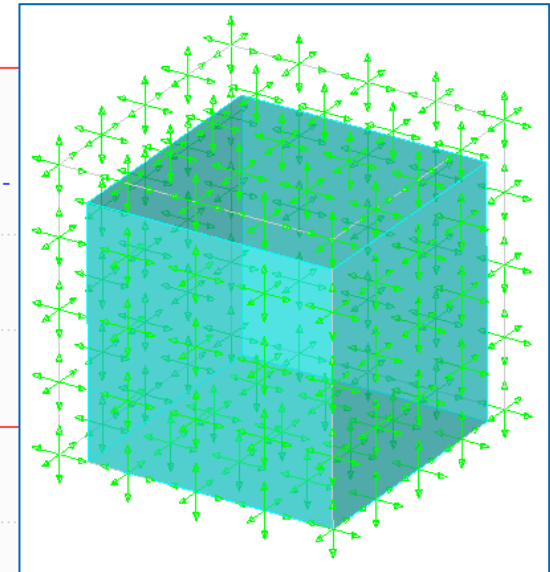
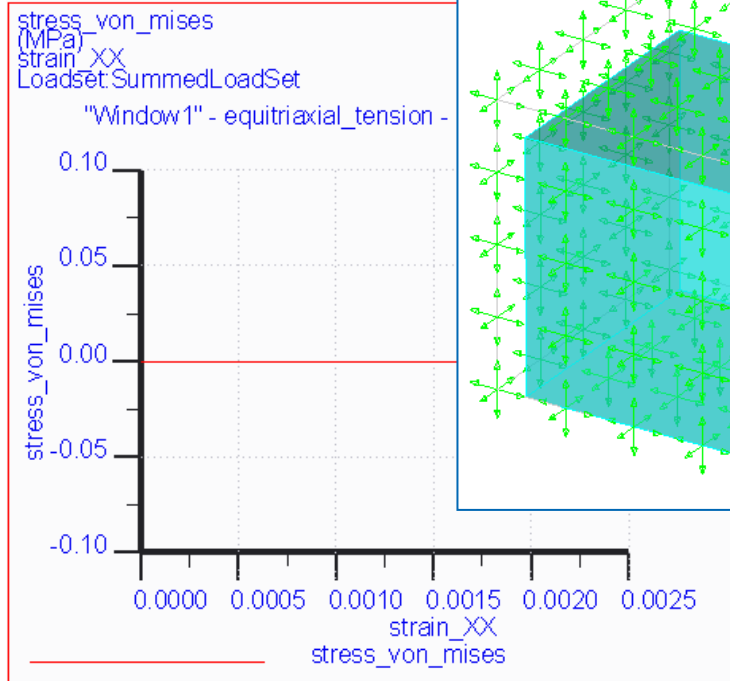
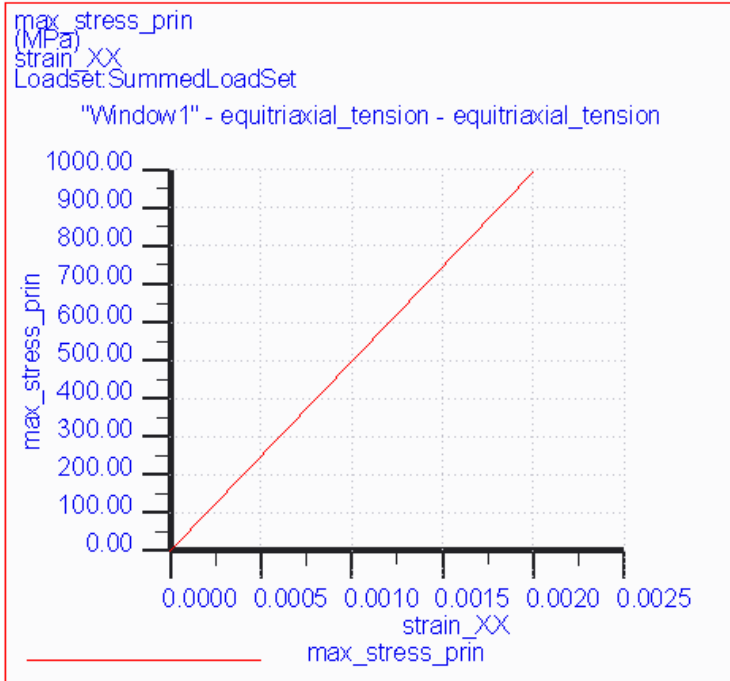
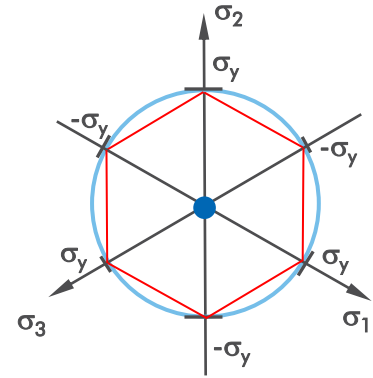

Basics of material hardening

■ Bauschinger effect

- If a metallic material is loaded above its yield strength and the load is reversed, its yield strength in the reversed direction becomes reduced
- This effect was described by Johann Bauschinger (1834-1893, Prof. for engineering mechanics at the Munich Polytechnikum)
- The analogous model for this effect is shown right below: It consists of a spring K_1 representing the elastic material behavior. In serial connection to K_1 , there is a friction element F_R and another spring K_2 (usually $K_2 \ll K_1$) in parallel connection

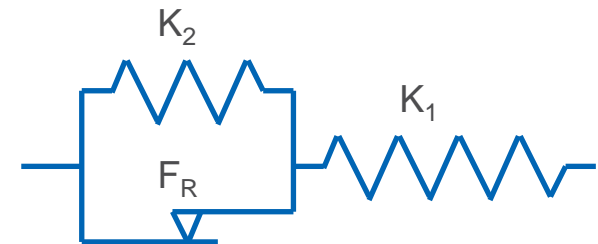
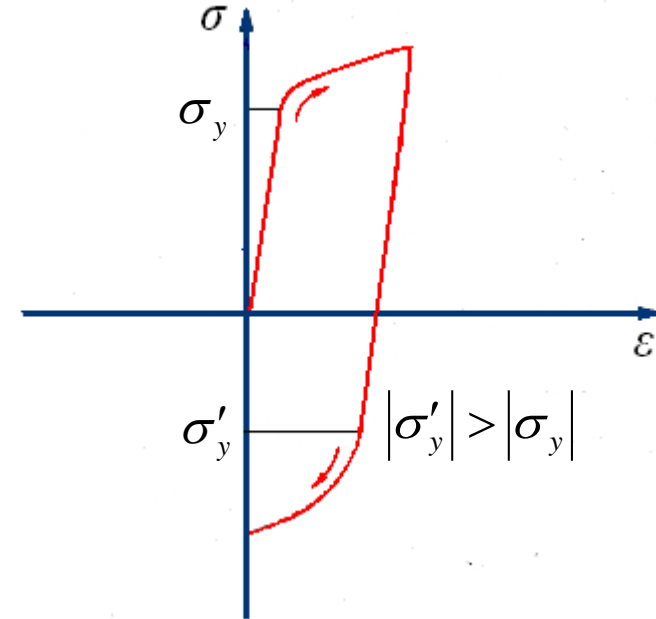

Basics of material hardening

- **Kinematic hardening (Bauschinger effect)**
 - Ideal kinematic hardening means that the yield surface of the yield law is just offset, its size remains unchanged
 - The yield limit is constant, just the midpoint “m” of the yield locus changes
- **Isotropic hardening**
 - For ideal isotropic hardening, the direction of the loading does not influence the yield limit
 - Here, the yield surface simply expands if the material is loaded above yield
- **Isotropic kinematic hardening**
 - In reality, usually both models have to be combined to describe the material behavior.
 - The Bauschinger number describes the relation of kinematic and isotropic hardening

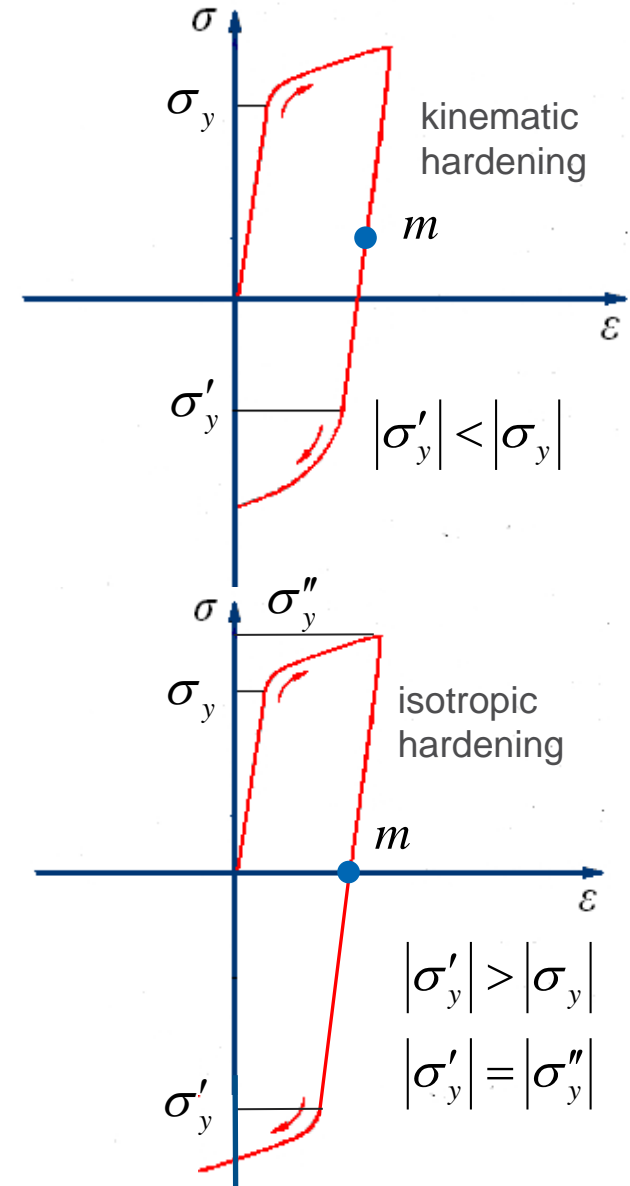

Part II

Applying Simulate to Elasto-Plastic Problems

Opportunities & Limitations
Tips & Tricks

Application in Creo Simulate (1)

- **Isotropic hardening**

- Creo Simulate supports isotropic hardening only, therefore currently the Bauschinger effect cannot be described

- **Example**

- Simple linear hardening material used

- **Load history:**

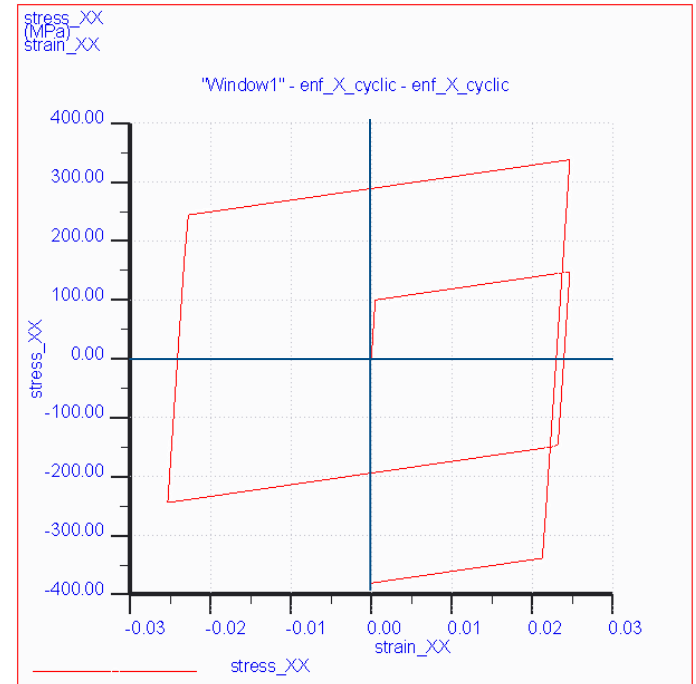
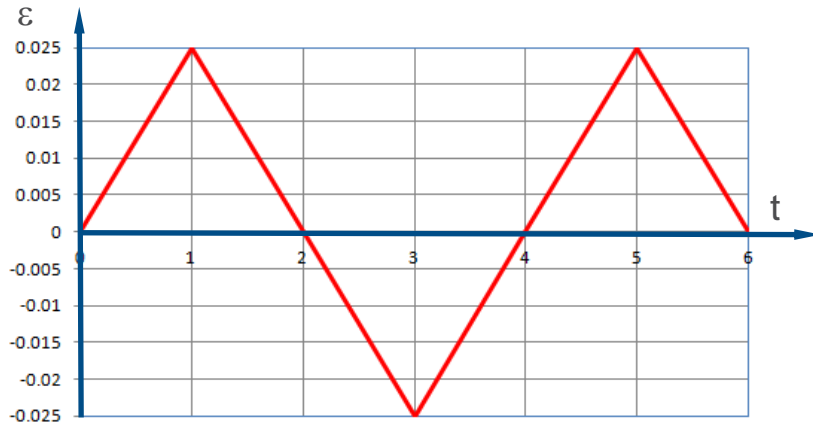

Application in Creo Simulate (2)

■ Cyclic Loading

- Since currently only isotropic hardening is supported, cyclic loading especially with the linear hardening or Power law is not realistic, because the material will “harden until infinity”.

■ Preferred Material Model

- In this case, approximate with perfect plasticity or exponential hardening law (both have an upper limit).

■ Load history

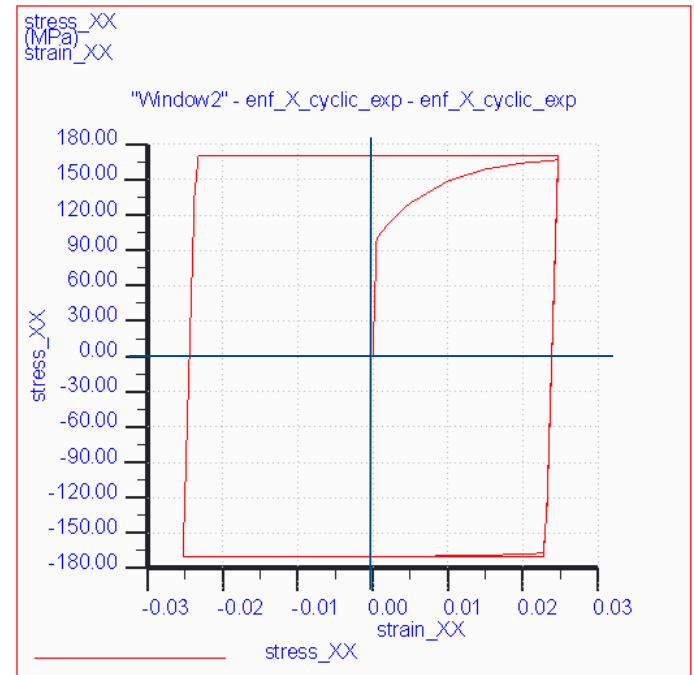
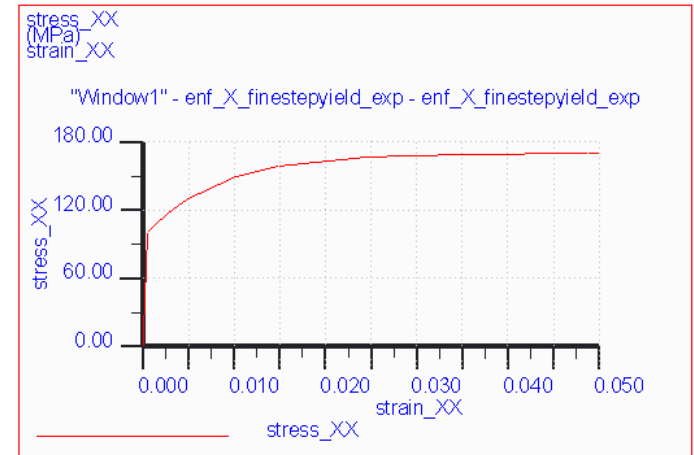
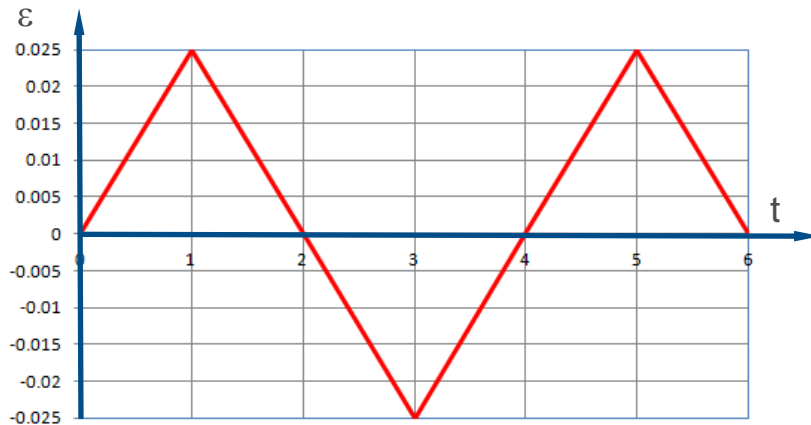

What do I have to take care about when I use a material law within Simulate?

■ Plastic material laws and test data

- When entering the elasto-plastic material/test data into the data dialogue, note that you have to enter engineering stress vs. engineering plastic strain for SDA and true stress vs. logarithmic plastic strain for LDA. Subtract the elastic strain from the total strain to get the plastic strain required for input. Note the curves start with the yield limit stress, not at zero!
- For all material laws except of perfect plasticity, the entered stress must be a strictly monotonic function of the engineering strain. A decrease of engineering stress at higher strains cannot be described in a SDA (see example 1 of part III for further details).
- Only the exponential plasticity law allows to define an upper limit of plastic stress, which is approached asymptotic!
- The material laws do not allow to calculate (accidentally) necking under high loads in the plastic domain, if there is no imperfection in the model; so they do not allow to predict where failure will really appear (see again example 1 of part III for further details).

■ Stress and strain output

- Note that Simulate will output engineering stress and strain in plasticity only if “calculate large displacements” (=LDA) is not activated. If an LDA is performed, since Creo 1.0 Simulate outputs logarithmic strain and true stress (until Wildfire 5, output is Almansi (Eulerian) strain).

Graphical representation of different strains [2]:

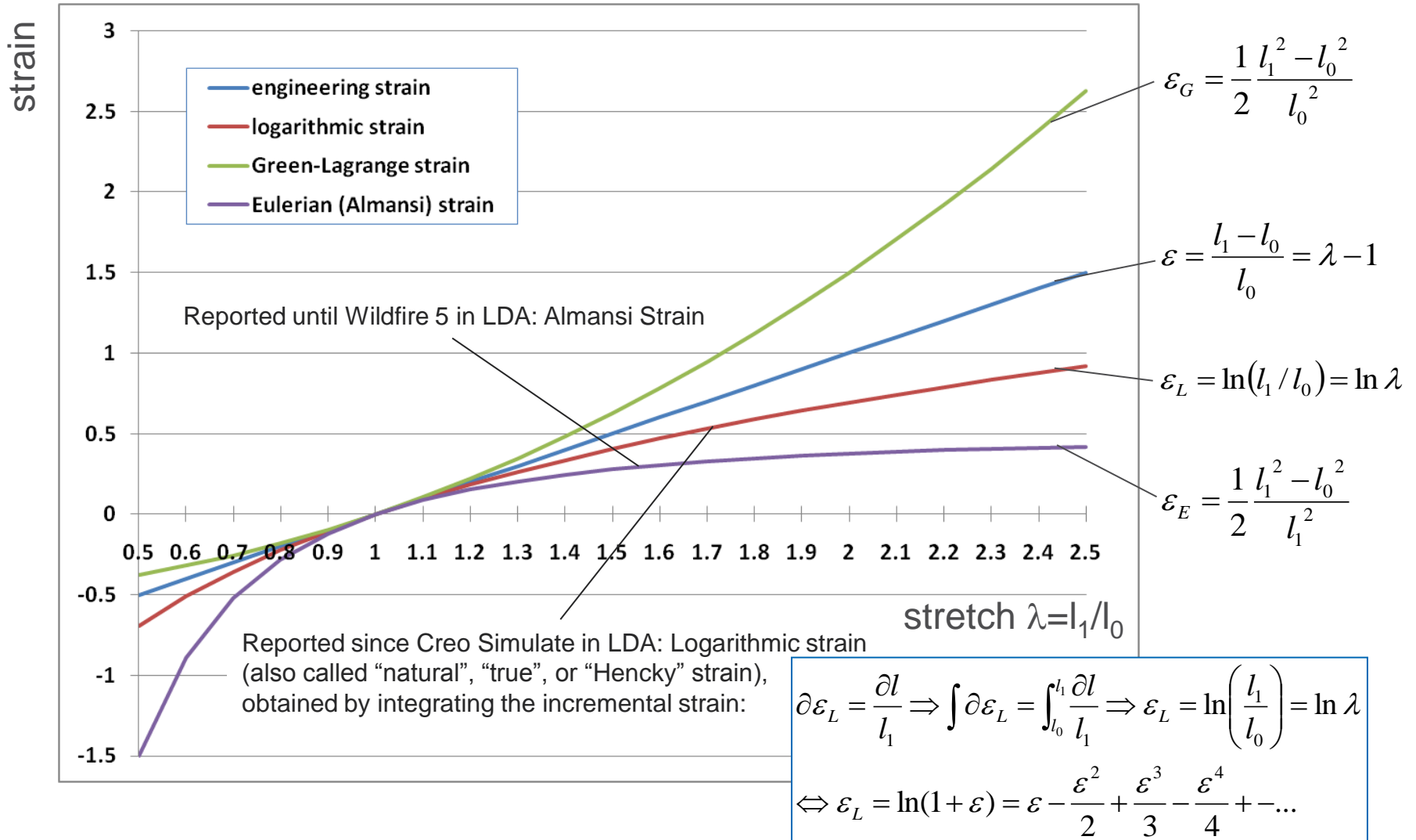

Small and finite strain plasticity

- Literature separates between “small strain” and “finite strain” plasticity
 - In small strain plasticity, just small deformations are allowed and the total deformations as well as the deformation increments are additively split into an elastic and plastic part, $\varepsilon = \varepsilon_e + \varepsilon_p$. This assumption is valid for strains up to a few percent, then it becomes inaccurate
 - In finite strain plasticity theory, the deformation gradient is split multiplicatively into an elastic and a plastic part. This allows to treat problems with very large deformations, like forging processes.
 - The mathematical methods especially of finite strain plasticity are very ambitious and far beyond the scope of this presentation.

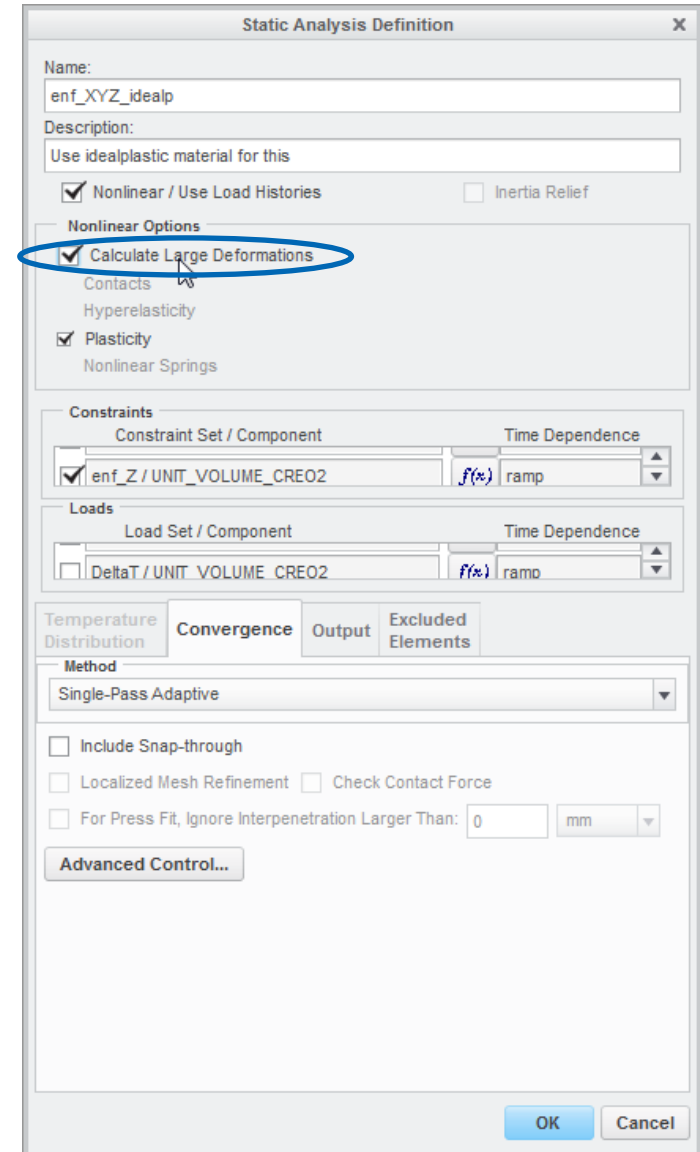

Mechanica WF 5.0 and Creo Simulate differ in plasticity models

- **Creo Elements / Pro Mechanica WF 5.0 supports small strain plasticity**
 - Here, the relation between total strain and displacement is linear: Strains are output as engineering values.
 - Plasticity is limited to SDA (small displacement analysis) only, LDA (large displacement analysis) therefore is not supported in this release
- **Creo Simulate 1.0 and 2.0 also support finite strain plasticity:**
 - Finite strain is implemented for 3D models if LDA is activated.
 - In this case, the plastic (and elastic) strain is output as logarithmic strain: Simulate computes incremental strain at each load step and then integrates it to get total strain. This ends up with strain being logarithmic (see slide 42).
 - For 2D models (plane stress, strain & axial symmetric), still just small strain plasticity is supported. So if LDA is used with these model types even though, e.g. in combination with a contact analysis, hyperelastic material, or nonlinear spring, Simulate issues a warning if the strain becomes $> 10\%$
 - Internally, the engine still uses large displacement calculations in this case, but the strain calculations in the 2D elasto-plastic elements themselves are small strain.

Performing finite strain analyses

- What can I do if I need finite strain calculations, but have a 2D problem?
 - In these cases (plane stress, plane strain or axial symmetric models), built up your model as 3D segment with a small angle or thin slice using appropriate constraints and mesh controls
 - Example: An axial symmetric problem as 2D axial symmetric and as 3D segment model:

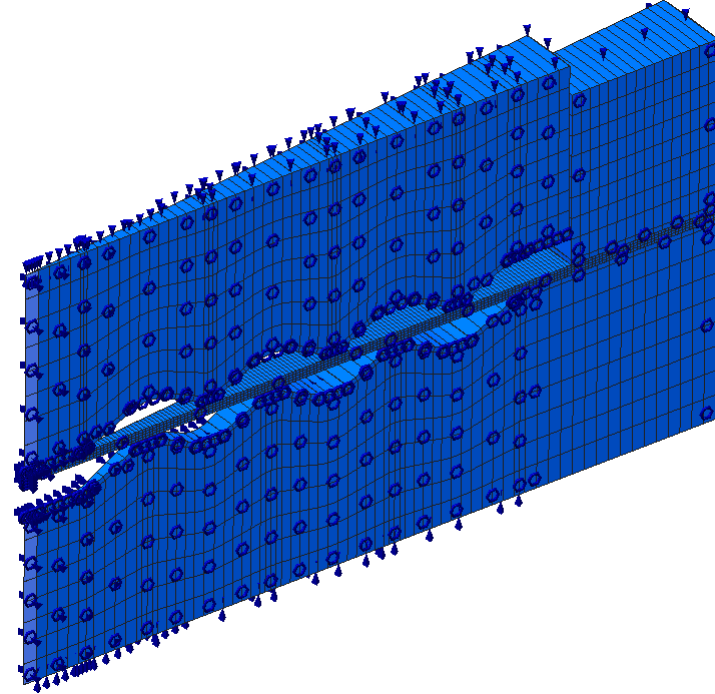
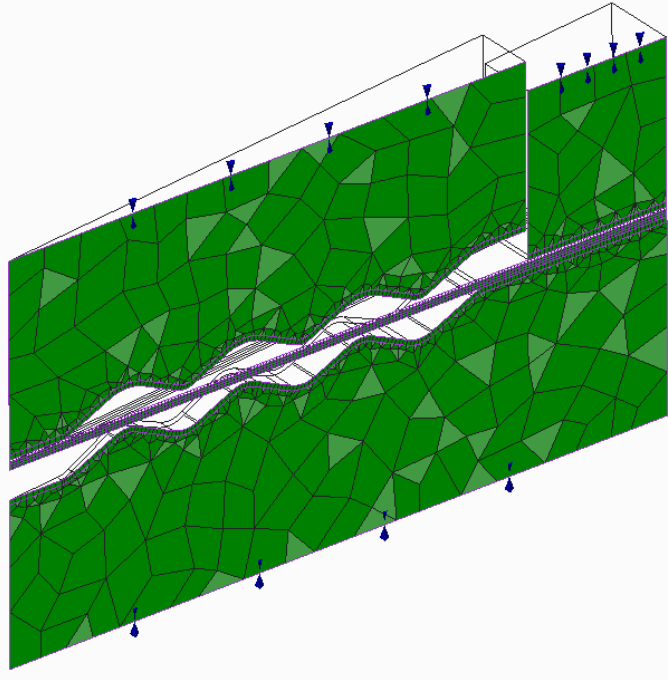

- Plane strain models can be set up by using just one layer of elements over the constant “slice” thickness and use mirror symmetry constraints at the slice cutting surfaces, see [10].

Equivalent plastic strain

■ How is the “equivalent plastic strain” being computed?

- The computation uses the following variables:

“**effectiveStressPredictor**”: current von Mises Stress

“**flowStress**”: yield stress based on current plastic strain and strain-hardening curve

“**ShearModulus**”: elastic shear modulus = $E/(2*(1+\nu))$ where ν is the elastic Poisson’s ratio

“**dep**”: incremental equivalent plastic strain

“**dStress**”: the slope of the work hardening curve

- At each load increment, the incremental plastic strain “dep” is given by:

dep = 0

Loop until **ddep** stops changing:

{

yieldFunction = **effectiveStressPredictor** - **flowStress** - 3.0***ShearModulus*****dep**

denominator = 3.0***ShearModulus** + **dStress**;

ddep = yieldFunction/denominator;

dep = **dep** + **ddep**;

}

- After this loop, the equivalent plastic strain “ep”, is incremented by “dep”. Note ep is logarithmic strain, like all strain quantities in LDA since Creo Simulate 1.0.

Von Mises Stress and Strain

■ Von Mises Stress

- Von Mises stress is derived under the assumption that distortion energy of any arbitrary loading state drives the damage of the material:

$$\sigma_{vM} = \sqrt{\frac{1}{2} \{ (\sigma_1 - \sigma_2)^2 + (\sigma_2 - \sigma_3)^2 + (\sigma_3 - \sigma_1)^2 \}}$$

- Per definition, in an uniaxial tension test case with just $\sigma_1 > 0$ and $\sigma_2 = \sigma_3 = 0$ we obtain for the von Mises Stress:

$$\sigma_{vM} = \sqrt{\frac{1}{2} \{ (\sigma_1)^2 + (-\sigma_1)^2 \}} = \sigma_1$$

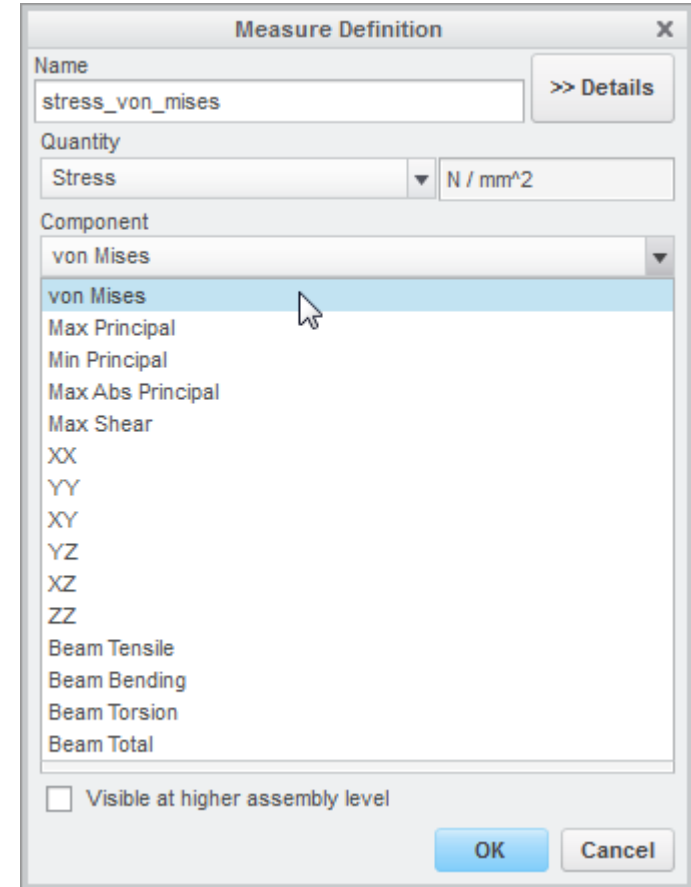

Von Mises Stress and Strain

■ Von Mises Strain in Simulate

- Simulate currently uses this equation for von Mises Strain:

$$\varepsilon_{vM} = \sqrt{\frac{1}{2} \{ (\varepsilon_1 - \varepsilon_2)^2 + (\varepsilon_2 - \varepsilon_3)^2 + (\varepsilon_3 - \varepsilon_1)^2 \}}$$

- This equation is used in formal analogy to the von Mises stress only for computational reasons (same subroutine as for stress) and simplicity.
- This strain will be analyzed on demand as measure output only for certain locations or over certain references. It is calculated at the end only and not used for any other result output.
- Note that this von Mises strain definition cannot be used directly for comparison with the longitudinal strain in an uniaxial test. It must be modified, e.g. with help of a computed measure, like shown in the subsequent slides.

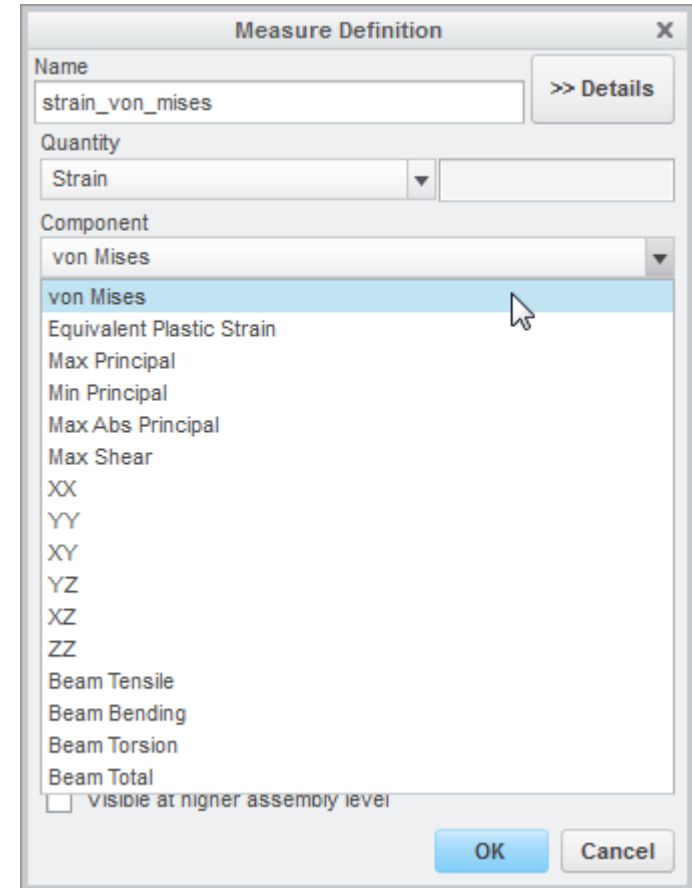

Von Mises Strain modification

■ Von Mises Strain

- In analogy to the von Mises stress, for comparing any three dimensional loading state with the state of uniaxial loading the von Mises strain definition in Simulate must be corrected: An additional factor $1/(1+\nu')$ should be taken into account, like e.g. used in [5]:

$$\varepsilon_{vM} = \frac{1}{1+\nu'} \sqrt{\frac{1}{2} \left\{ (\varepsilon_1 - \varepsilon_2)^2 + (\varepsilon_2 - \varepsilon_3)^2 + (\varepsilon_3 - \varepsilon_1)^2 \right\}}$$

- Herein, ν' is the effective Poisson's ratio, which is 0.5 for plastic strains (incompressible) or the material Poisson's ratio for elastic and thermal strains
- The following slides show that this equation reflects a scalar comparative strain for comparison with the longitudinal strain in a uniaxial test

■ Difficulties in von Mises strain correction

- If the loading state of the material is just in the elastic domain, this correction can be easily applied, since the elastic Poisson's ratio is known
- If the loading state is far in the plastic domain, the elastic deformation can be neglected and ν' becomes ≈ 0.5
- The problem is the domain with small plastic deformations, since here it is not known which strain type prevails, so which fraction of the deformation is plastic and which is elastic

Von Mises Strain definition in the uniaxial case

■ Hooke's law

- Hooke's law for isotropic material expressed in principal stresses and strains:

$$\varepsilon_1 = \frac{1}{E} \{ \sigma_1 - \nu(\sigma_2 + \sigma_3) \}$$

$$\varepsilon_2 = \frac{1}{E} \{ \sigma_2 - \nu(\sigma_1 + \sigma_3) \}$$

$$\varepsilon_3 = \frac{1}{E} \{ \sigma_3 - \nu(\sigma_1 + \sigma_2) \}$$

- In an uniaxial tensile test, we have just one positive principal stress σ_1 , resulting in a three-dimensional strain state:

$$\sigma_1 = F / A$$

$$\sigma_2 = \sigma_3 = 0$$

$$\varepsilon_1 = \frac{1}{E} \sigma_1$$

$$\varepsilon_2 = \varepsilon_3 = -\frac{\nu}{E} \sigma_1$$

- The von Mises comparative strain equation should deliver the same strain like the axial strain ε_1

Von Mises Strain definition in the uniaxial case

■ Von Mises Strain

- Let's examine if the corrected von Mises Strain definition works correct for uniaxial loading, where we have:

$$\sigma_1 = F / A; \quad \sigma_2 = \sigma_3 = 0$$

$$\varepsilon_1 = \frac{1}{E} \sigma_1; \quad \varepsilon_2 = \varepsilon_3 = -\frac{\nu}{E} \sigma_1$$

- Putting this into the von Mises Strain equation, we obtain with $\nu = \nu'$:

$$\varepsilon_{vM} = \frac{1}{1+\nu} \sqrt{\frac{1}{2} \left\{ \left(\frac{1}{E} \sigma_1 + \frac{\nu}{E} \sigma_1 \right)^2 + \left(-\frac{\nu}{E} \sigma_1 + \frac{\nu}{E} \sigma_1 \right)^2 + \left(-\frac{\nu}{E} \sigma_1 - \frac{1}{E} \sigma_1 \right)^2 \right\}}$$

$$\varepsilon_{vM} = \frac{1}{1+\nu} \sqrt{\frac{1}{2} \left\{ 2 \left(\frac{1}{E} \sigma_1 + \frac{\nu}{E} \sigma_1 \right)^2 + 0^2 \right\}} = \frac{1}{1+\nu} \left(\frac{1}{E} \sigma_1 + \frac{\nu}{E} \sigma_1 \right) = \frac{1}{E} \sigma_1 \frac{1}{1+\nu} (1+\nu)$$

$$\varepsilon_{vM} = \frac{1}{E} \sigma_1 = \varepsilon_1 \quad \text{q.e.d.}$$

- So, per definition now the von Mises Strain equation delivers the uniaxial tensile strain ε_1 for the uniaxial loading state

What do I have to take care about if I want to load my structure?

■ Loading

- Creo Simulate offers a powerful time history functionality using “dummy time” steps.
- Load stepping is available in two ways:
 - The user can use default or self-defined functions, e.g. as tabular values. In this case, output steps should be kept “automatic”, then for all tabular time values a result will be computed
 - Output steps can also be set to “User defined”, with automatic or manual time stepping.
- Simulate has a built-in automatic load step refinement in case of too big increments, but this should not be overstressed!
- A good user load stepping can significantly increase performance!

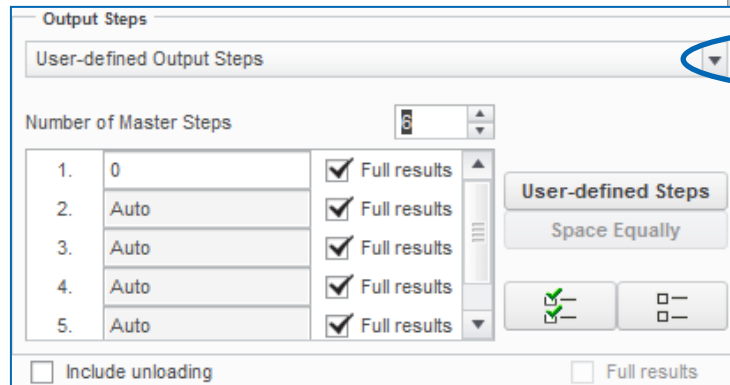
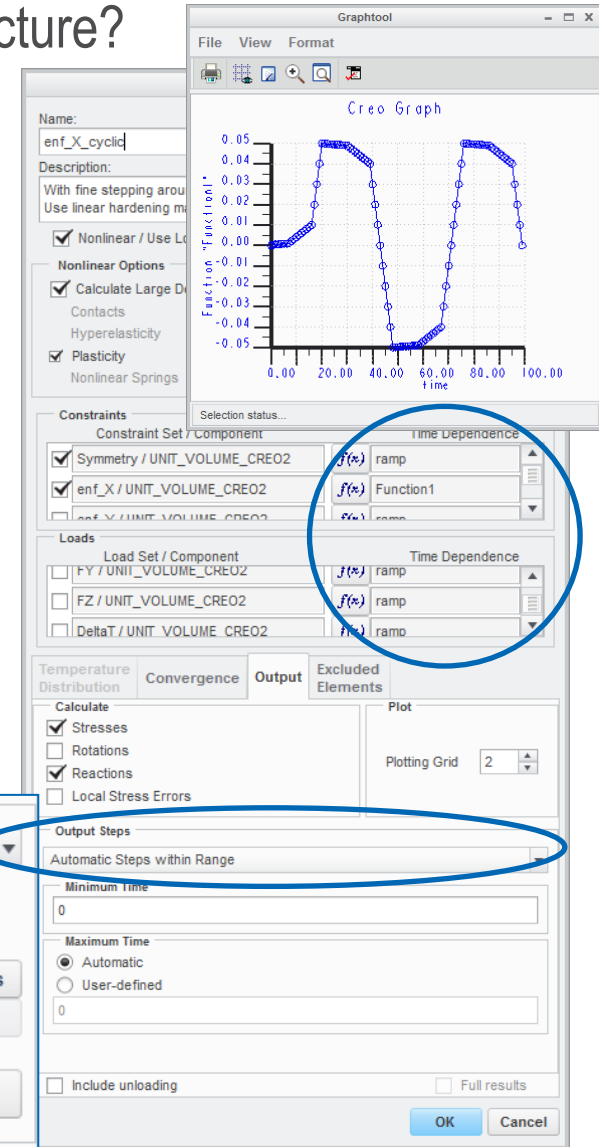

What do I have to take care about if I want to unload my structure?

■ Unloading

- Unloading can be achieved by simply activating the button “include unloading”.
- Alternatively, since Creo 1 unloading can be achieved by using the new load history function just described.
- In addition, Creo 2.0 offers an engine command line option for advanced users called “lda_gradual_unloading” (unsupported for testing by advanced users only). This assures that unloading with the button “include unloading” is done not in one single, but a series of 10 consecutive steps.
- The reason for this command line option is that unloading the structure in one single step may lead in some cases to inaccurate results. Usually, this can be clearly detected by checking the von Mises stress distribution: It will look noisy, having many randomly located “hot spots” that are obviously not reasonable.

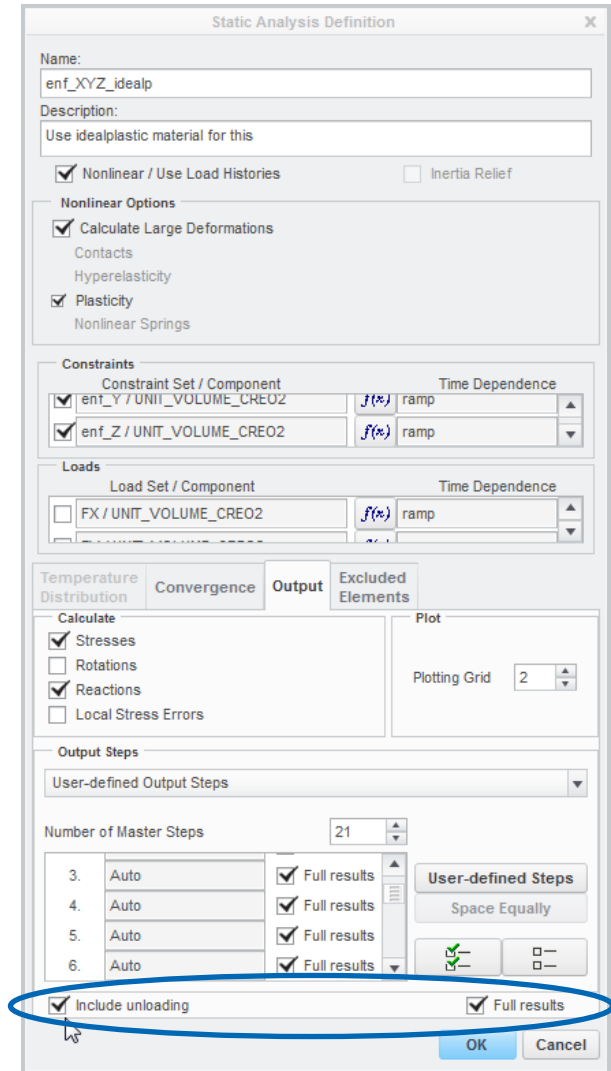

When using elasto-plastic materials, what do I have to take care regarding meshing?

- **Mesh controls**

- A good mesh in a nonlinear material analysis is much more important than in a linear analysis, because it helps the analysis to run faster or more accurate within the same time.
- Especially problems with very large strains take benefit of a smooth, undistorted mesh with bricks and wedges instead of tets.
- The new mesh controls for regular meshing should therefore be used whenever possible.

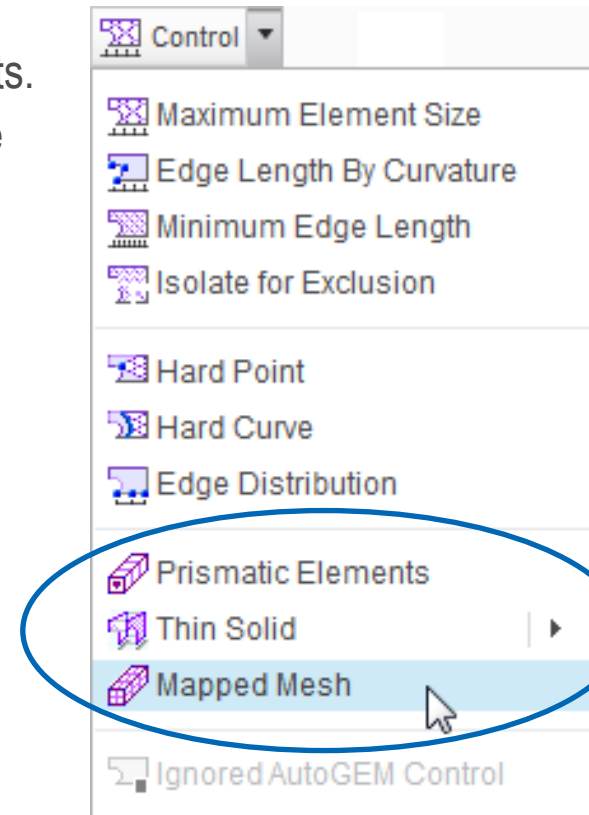
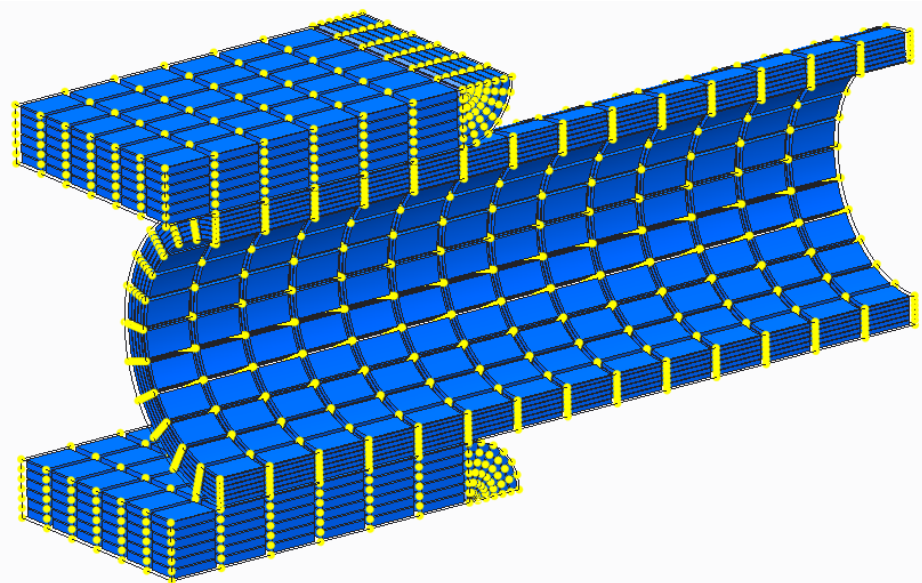

Part III

Application Examples

Study of a tensile test specimen with taking into account necking

■ Goals of the study:

- Understand why a uniaxial tension test specimen made of ductile material breaks in the necked area under 45° at the outer surface and brittle in its center (see slide 7 or [3])
- Understand differences of SDA and LDA in plasticity
- Understand the influence of necking in the true and engineering stress-strain curves

■ Remark:

- The material laws in Simulate do not directly allow to simulate necking in a perfect specimen with regular mesh, which appears in reality at an accidental weak location of the tensile test specimen.
- Therefore, we use a second cylindrical specimen in the LDA with a small imperfection modeled into the geometry like shown right: The cylinder radius is just locally $5/100$ mm smaller than the nominal radius of 10 mm
- We will analyze the perfect specimen in both SDA and LDA

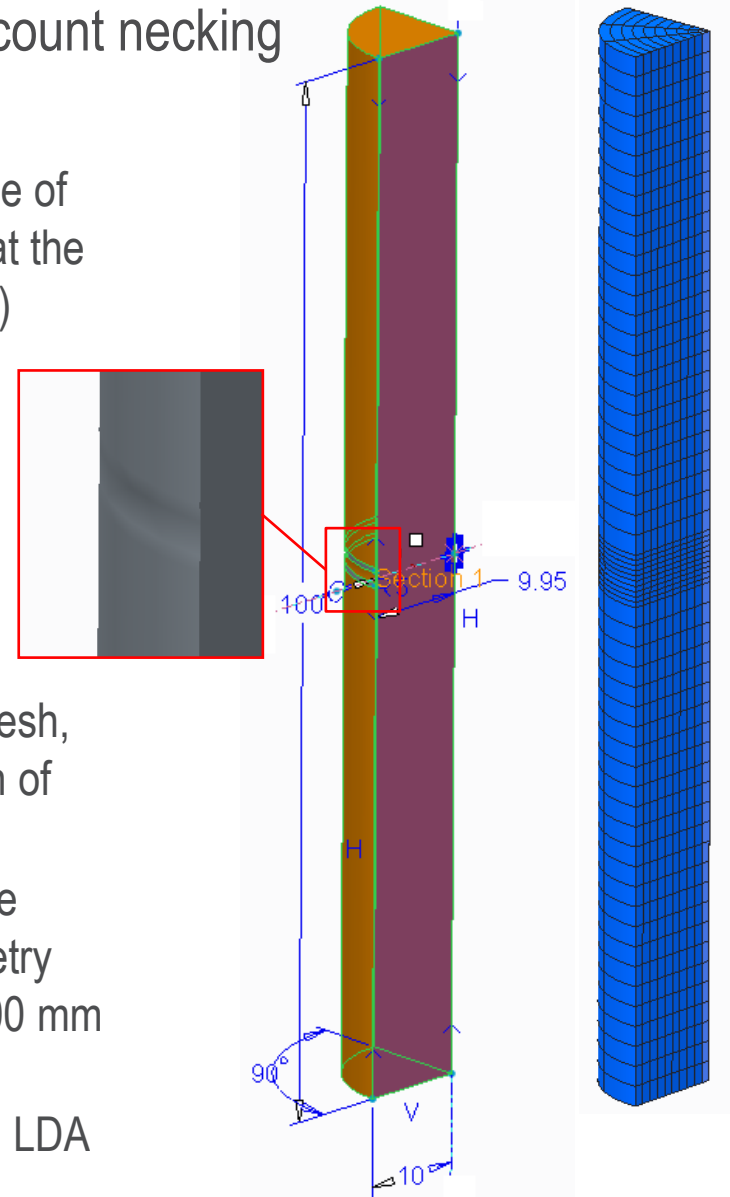

Study of a tensile test specimen with taking into account necking

■ Model setup:

- We use mapped meshing for the 90° symmetry section to obtain a regular mesh just using bricks (and wedges only at the rotation axis).
- From the reaction forces at the constraints, we analyze nominal engineering and true stress in the necked section with help of computed measures.
- Engineering strain (not output in LDA) is computed by the specimen elongation divided by its initial length (computed measure).
- We use an enforced displacement to apply the load, for better numerical stability in the region of high plastic strains.

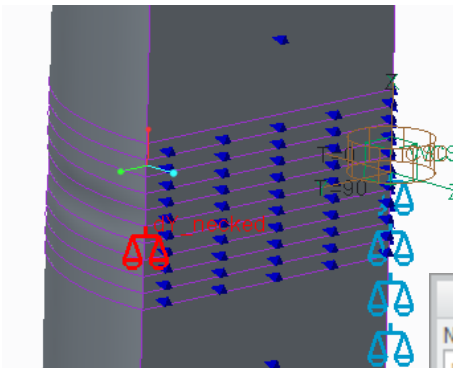

Measure Definition

Name: dY_necked

Quantity: Displacement

Component: Y

Coordinate System: WCS

Spatial Evaluation: At Point

Point(s): Vertex (EdgeStart)

Valid for Analysis Types: Static Analysis

OK Cancel

Measure Definition

Name: Force

Quantity: Force

Component: X

Coordinate System: WCS

Spatial Evaluation: Constraint1;

Valid for Analysis Types: Static Analysis

OK Cancel

Measure Definition

Name: A_true

Quantity: Computed Measure

Expression: $\pi(10+dY_necked)^2$

Valid for Analysis Types:

OK Cancel

Measure Definition

Name: true_stress

Quantity: Computed Measure

Expression: $Force / (\pi(10+dY_necked)^2 / 4)$

Valid for Analysis Types:

OK Cancel

Study of a tensile test specimen with taking into account necking

■ Used material:

- We use steel ($E=200$ GPa, $\nu=0.27$) with exponential material law ($m=10$)
- Yield limit is 210 MPa, ultimate limit is 330 MPa (engineering stress)
- Note that the material input data is interpreted as engineering stress vs. engineering strain in SDA and true stress vs. log (true) strain in LDA!

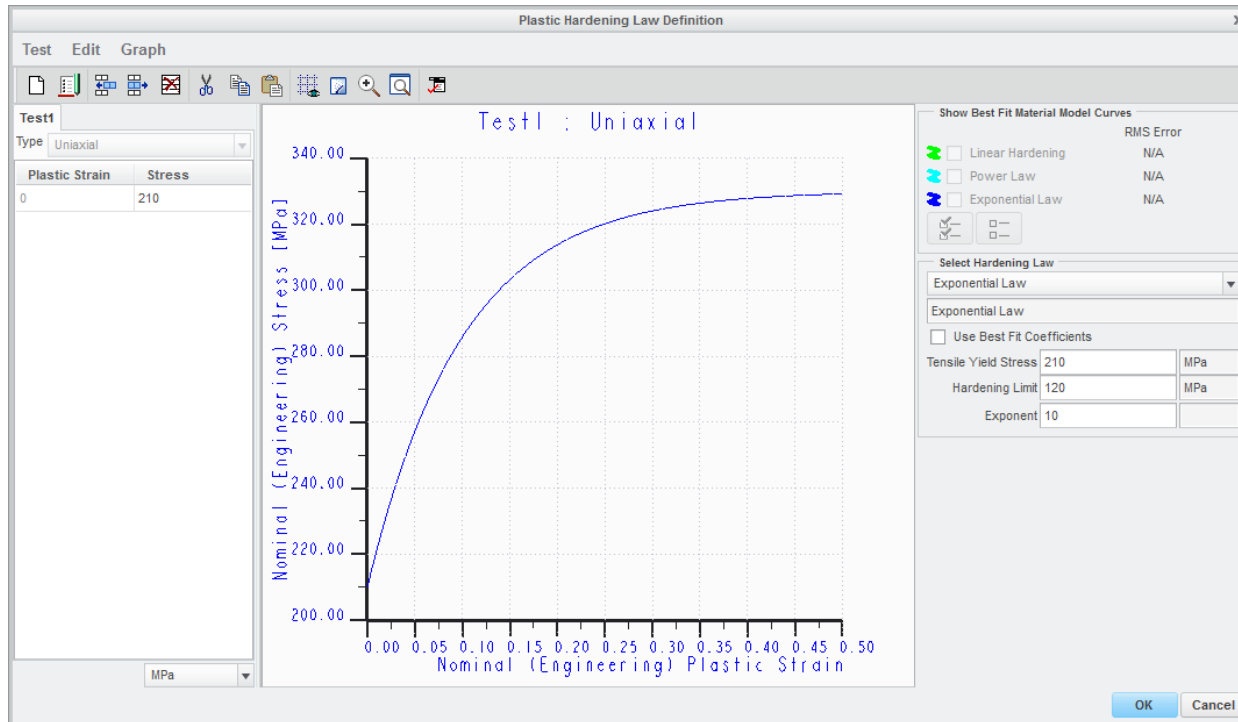

Study of a tensile test specimen with taking into account necking

- Imperfect specimen showing equivalent plastic strain with 1:1 deformations

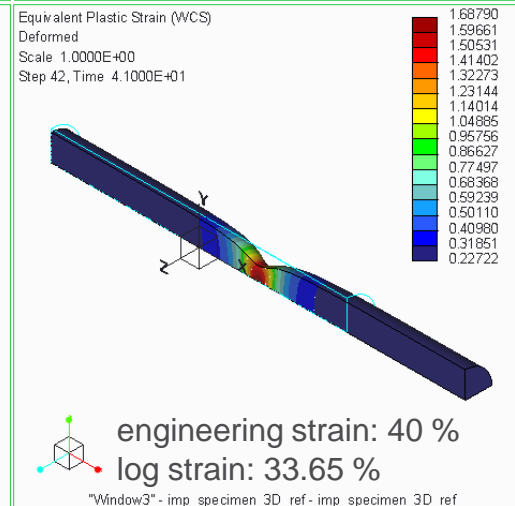
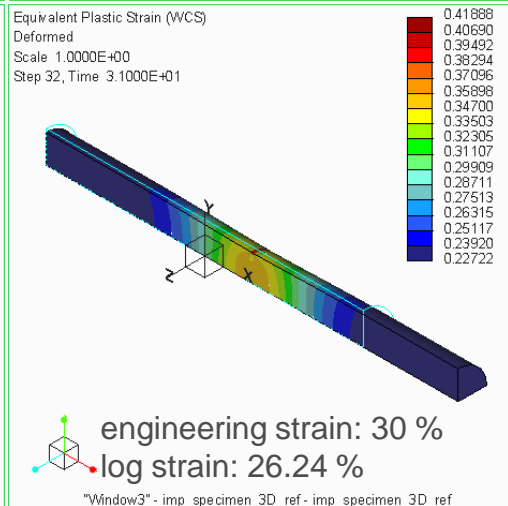
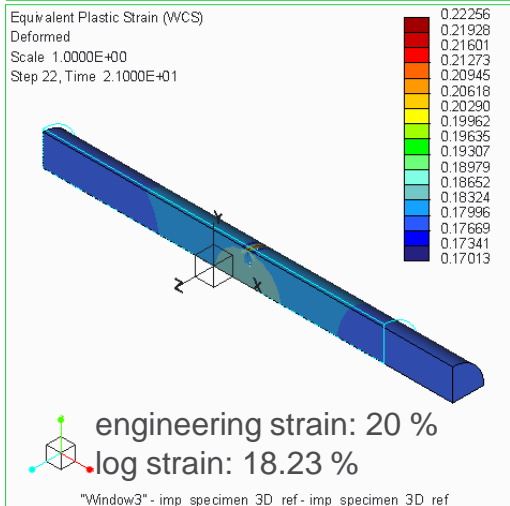
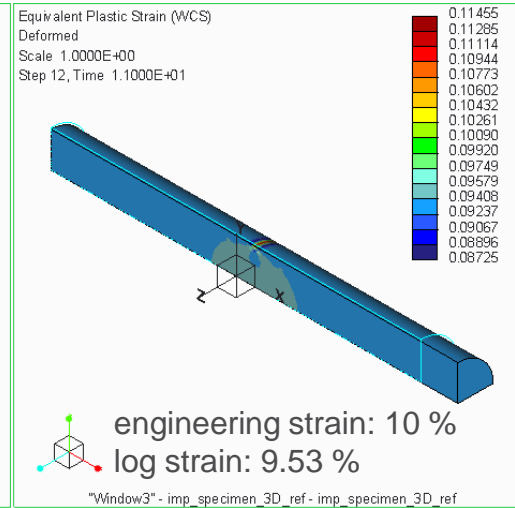
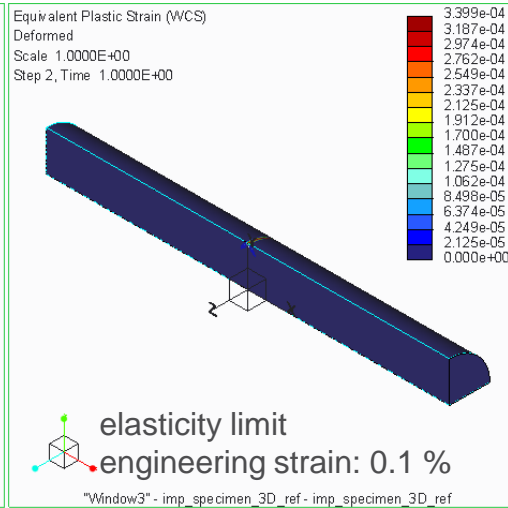
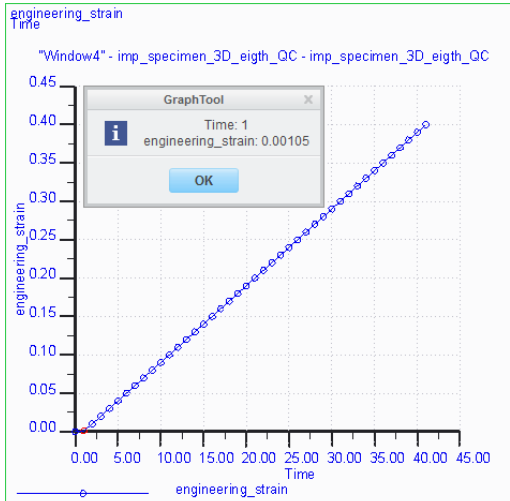

LDA results, shown is log strain.

Note: Axial strain is not constant along the specimen, the engineering and equivalent log strain values are an average!

$$\varepsilon = \frac{l_1 - l_0}{l_0}$$

$$\varepsilon_L = \ln(l_1 / l_0) = \ln \lambda$$

Study of a tensile test specimen with taking into account necking

- Equivalent plastic strain and von Mises stress results animations

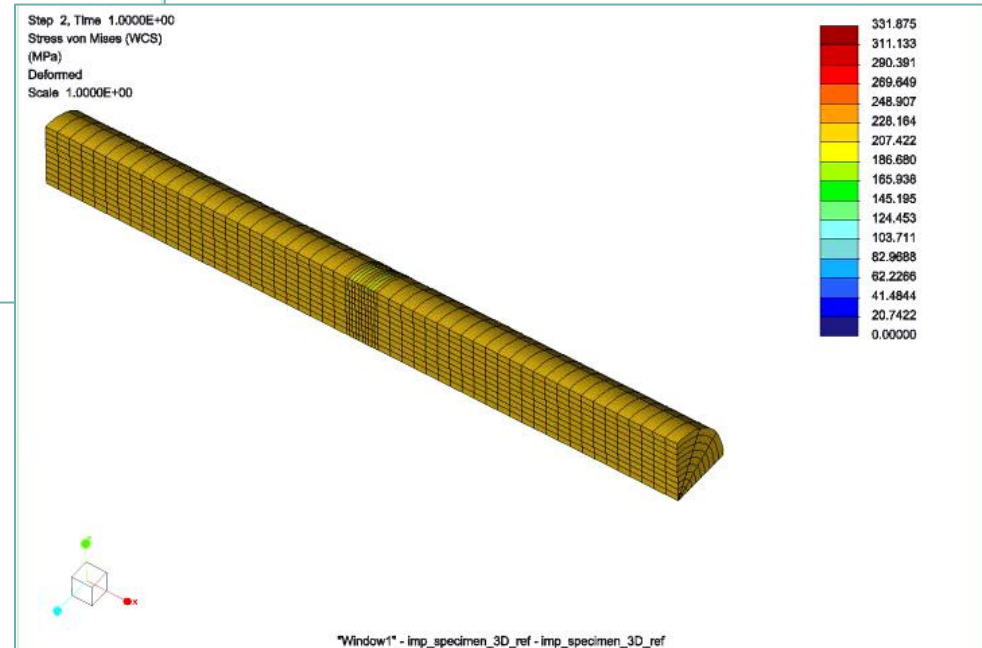
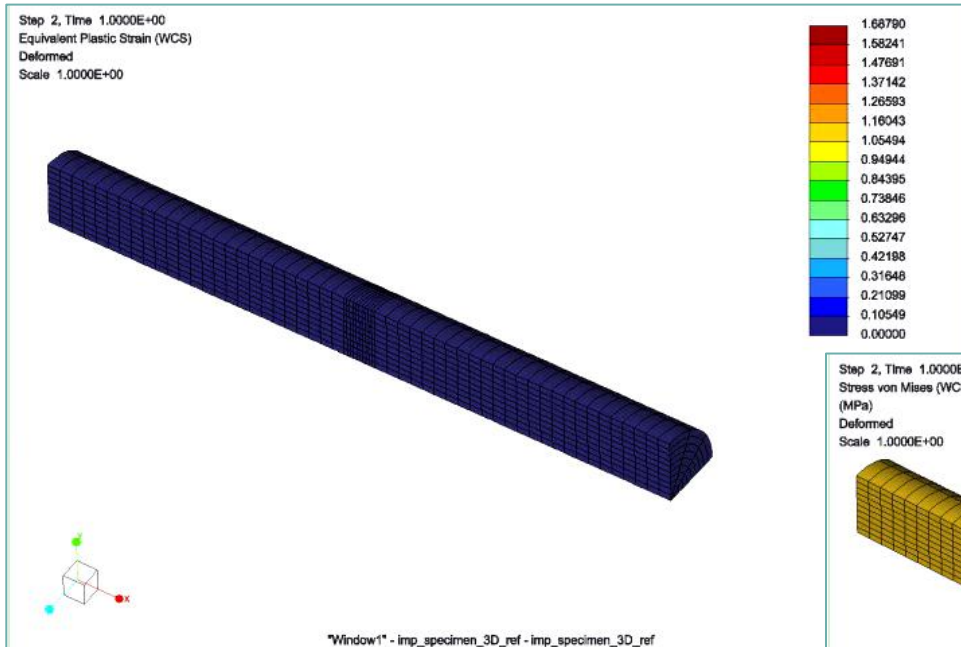

Study of a tensile test specimen with taking into account necking

- Principal stress vector results at max. engineering strain in the necked cross section center

- In the center of the necked region, a triaxial tensile stress state appears
- In our example, the three principal stresses are not the same like stated in [3], but in the specimen center radial and circumferential stress have similar size and are approximately 60 % of the axial principal stress
- Triaxial tension leads to brittle rupture in the specimen, whereas at the specimen surface we just have a two-axial stress state (radial stress=0): There, we have ductile behavior.

Stress All Prin (WCS)
(MPa)
Deformed Location: Surfaces
Scale 1.0000E+00
Step 42, Time 4.1000E+01

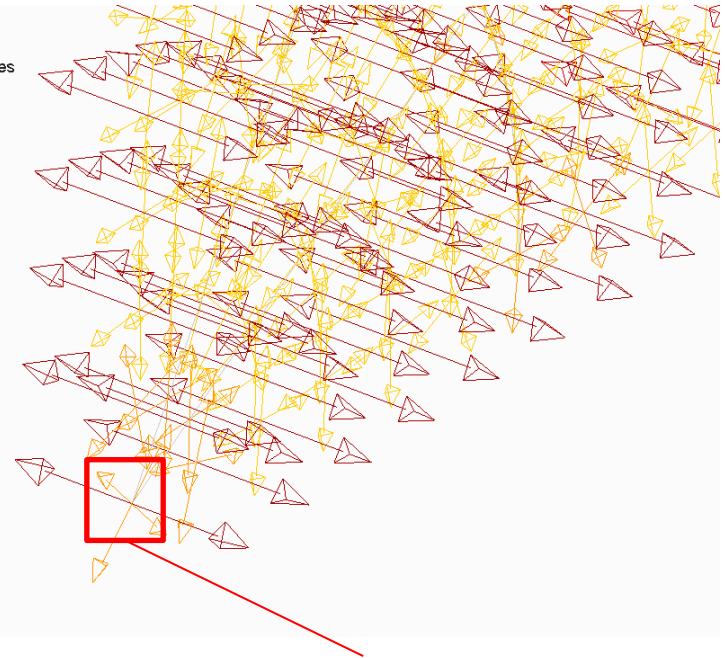

Triaxial tension
(Quick check results only)!

$$\sigma_1 = \sigma_{ax} \approx 886 \text{ Mpa}$$

$$\sigma_2 = \sigma_3 \approx 546 \text{ Mpa}$$

Study of a tensile test specimen with taking into account necking

- True and engineering stress vs. engineering strain in SDA and LDA

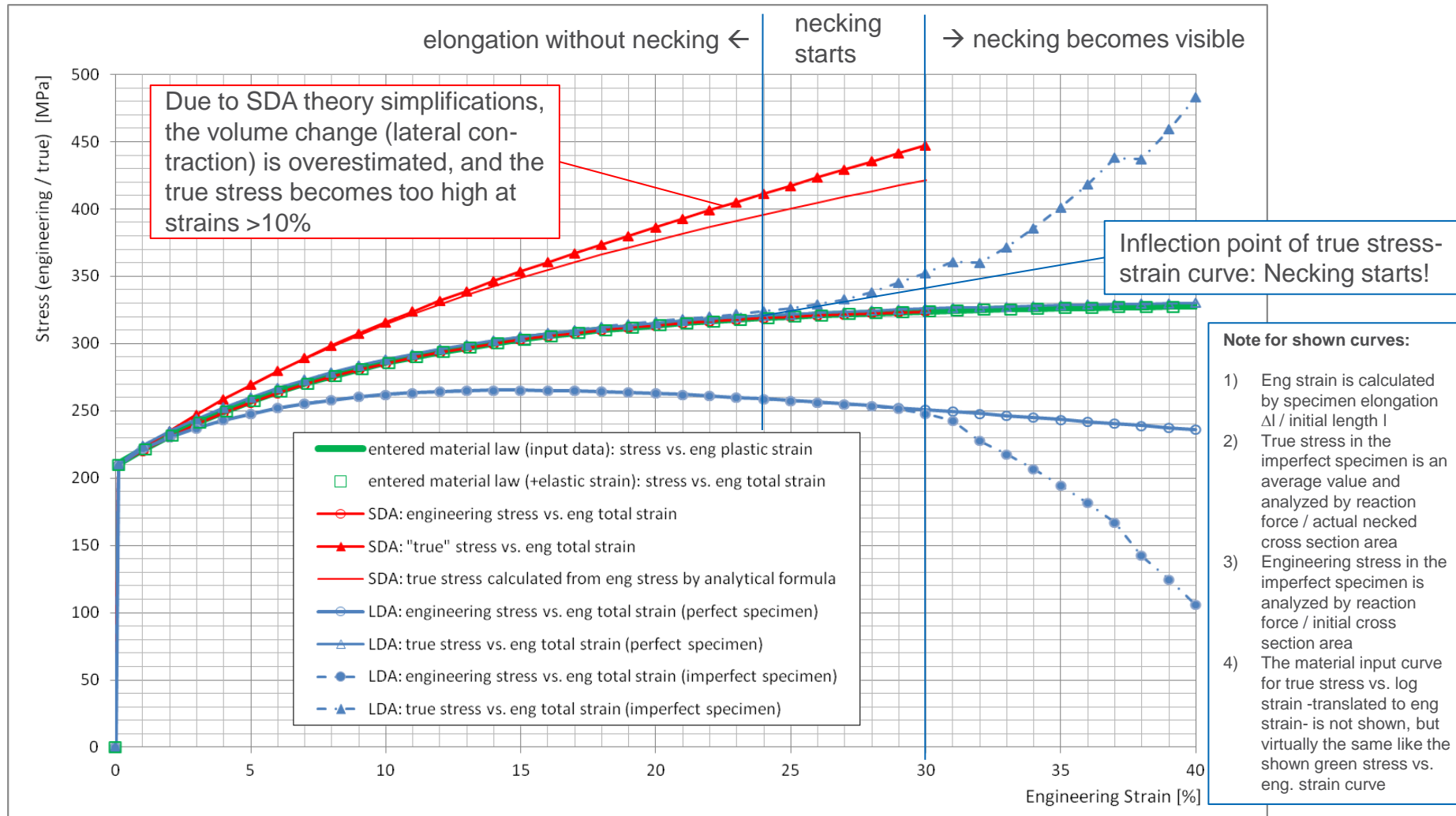

Study of a tensile test specimen with taking into account necking

■ Conclusions:

- The subtraction of elastic strain from the measured curve is just a small correction.
- Note that you may need different material data sets for SDA and LDA.
- For small strains, it is sufficient to measure engineering stress vs. engineering strain and run an SDA analysis.
- For bigger strains, e.g. 5% and more, true stress vs. true strain should be input into the material dialogue. Run an LDA analysis in this case! This is especially important if you want to do a metal forming analysis, where strains may rapidly become 30% and more.
- True stress results from specimens in the necked region should not be taken into account, since they will falsify the material data curve. Take care that you input data just from the strain region without necking (true stress curve has an inflection point when necking starts)!
- When necking appears, the axial strain along the specimen length is not constant any longer (see the animations on slide 60). A further increase of strain will just take place in the necked area.
- As a result check, you may run an analysis with your tensile test specimen and compare material data input curve and analysis result like shown in the example.

Study of a tensile test specimen with taking into account necking

■ Useful equations for uniaxial test data evaluation:

– For translating stress data: $\sigma_{true} = \sigma_{eng} (1 + \varepsilon_{eng})$
 $\sigma_{eng} = \sigma_{true} / \exp(\varepsilon_{ln})$

– For translating strain data: $\varepsilon_{ln} = \ln(1 + \varepsilon_{eng})$
 $\varepsilon_{eng} = e^{\varepsilon_{ln}} - 1$

$$\varepsilon_{eng,pl} = \varepsilon_{eng} - \frac{\sigma_{eng}}{E}$$

$$\varepsilon_{ln,pl} = \ln(1 + \varepsilon_{eng}) - \frac{\sigma_{true}}{E}$$

■ Summary of required stress/strain input in Simulate:

Material	SDA/LDA	Stress	Strain
hyperelastic	LDA (no hyperelasticity support in SDA)	nominal (engineering)	nominal (engineering)
elastoplastic	SDA (small strain)	nominal (engineering)	nominal (engineering)
elastoplastic	LDA (finite strain)	true	true (logarithmic)

Model setup

- **Geometry:**
 - Two ideal-elastic plates compress a soft Aluminum tube (displacement controlled)
 - Half symmetry model to increase speed
- **Material:**
 - Power law used for elasto-plastic description

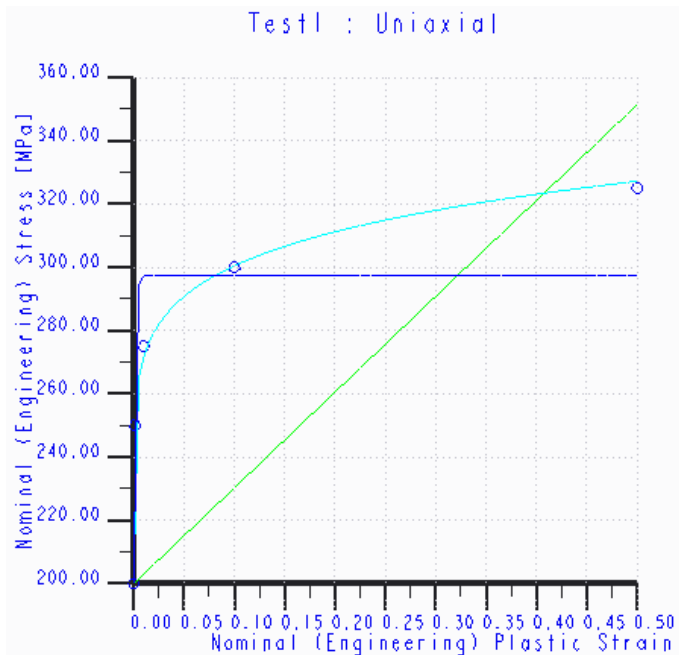
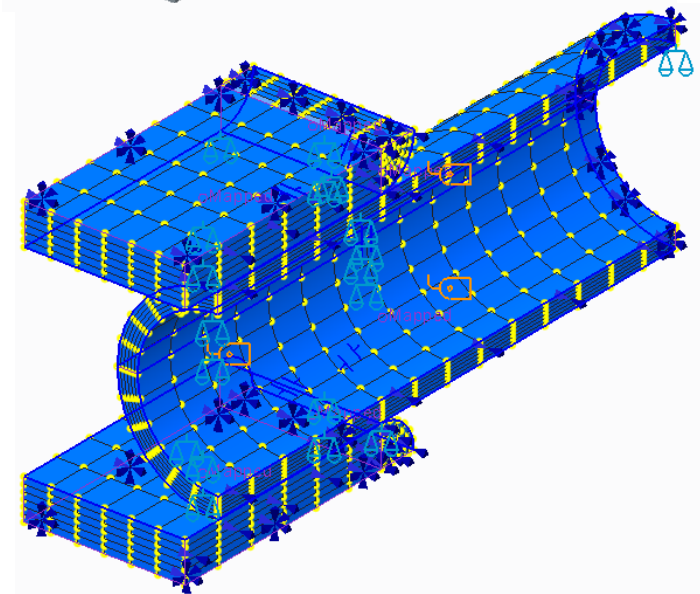
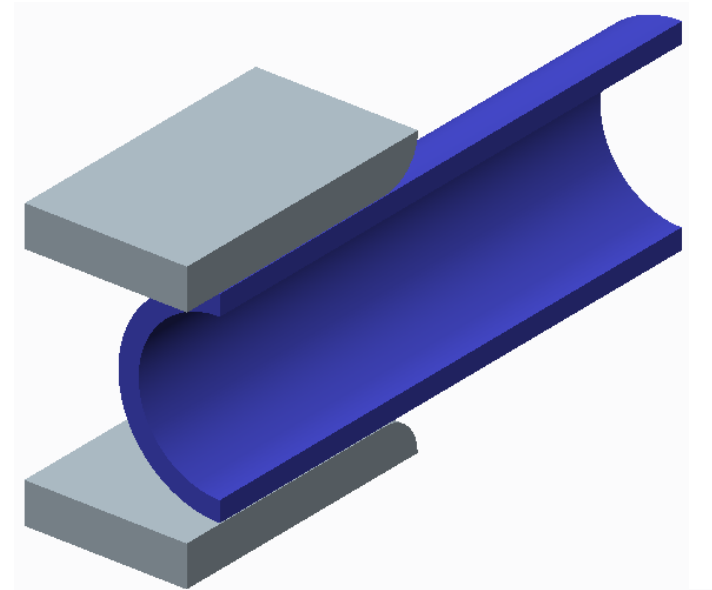

Flattening of a Tube End (2)

Displacement results animation (quick check only)

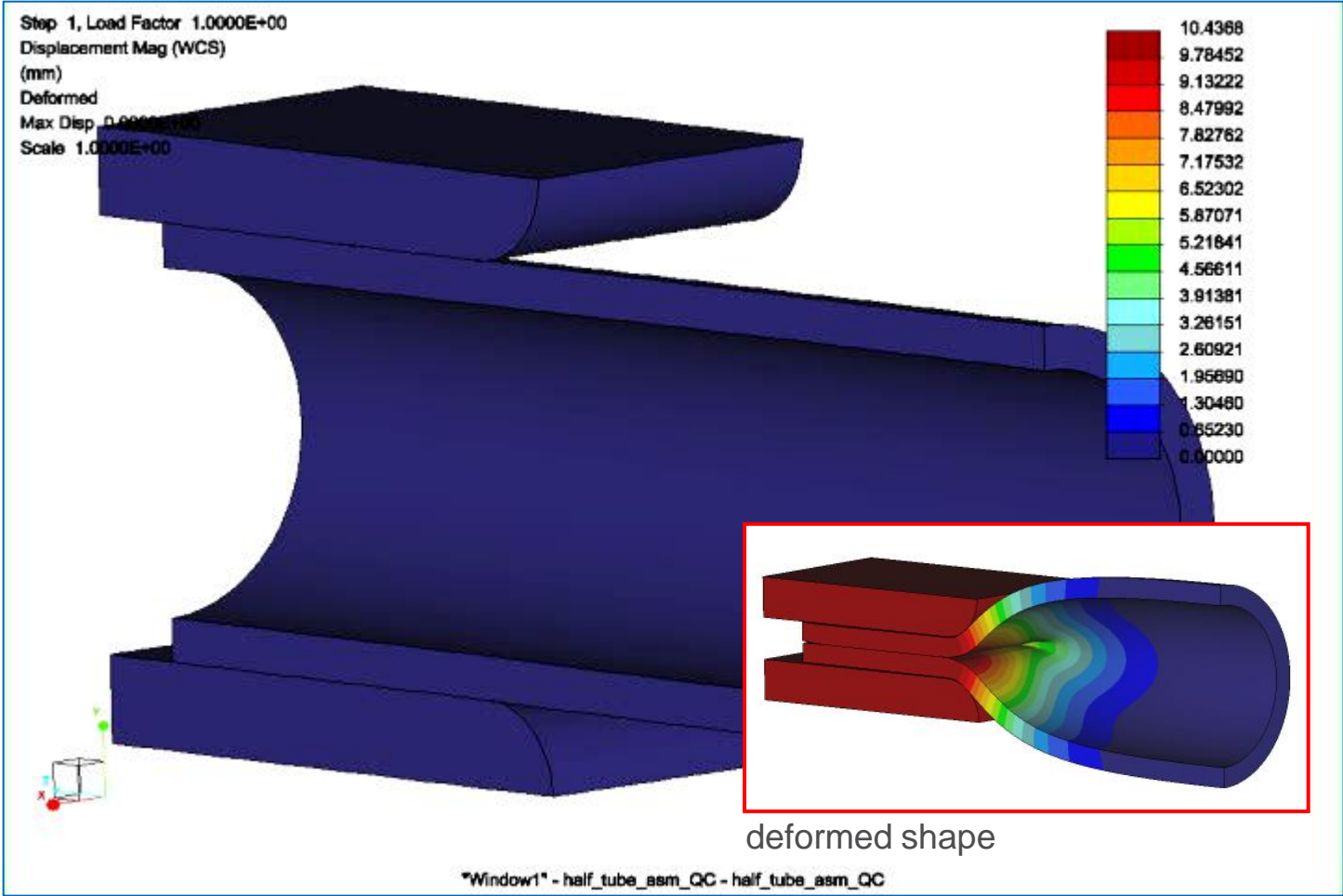

Von Mises stress results animation (quick check only)

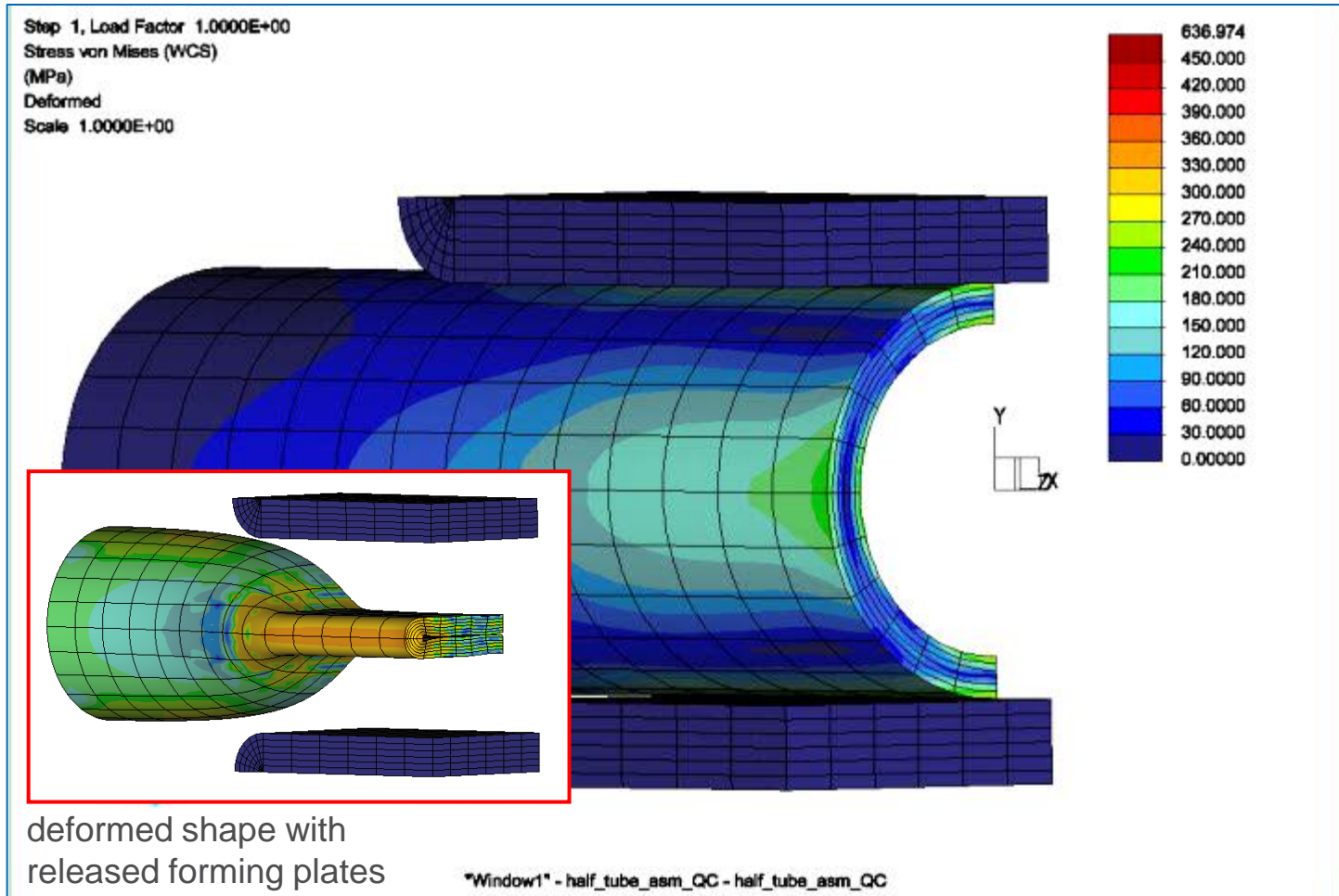

Model setup

■ Geometry:

- A thin flat steel disk is formed to become a membrane
- The steel disk is guided at the outer diameter with help of a ring
- The displacement controlled grey piston forms the wave

■ Model:

- For simplicity, the 2D axial symmetric model formulation is used.
- Note this is just a coarse approximation since we expect log strains of $>30\%$ and small strain plasticity is not accurate here. An alternative, better suitable 3D segment model supporting finite strain is shown on slide 45.
- LDA is used for better contact modeling, since we have large deformations at the contacts.

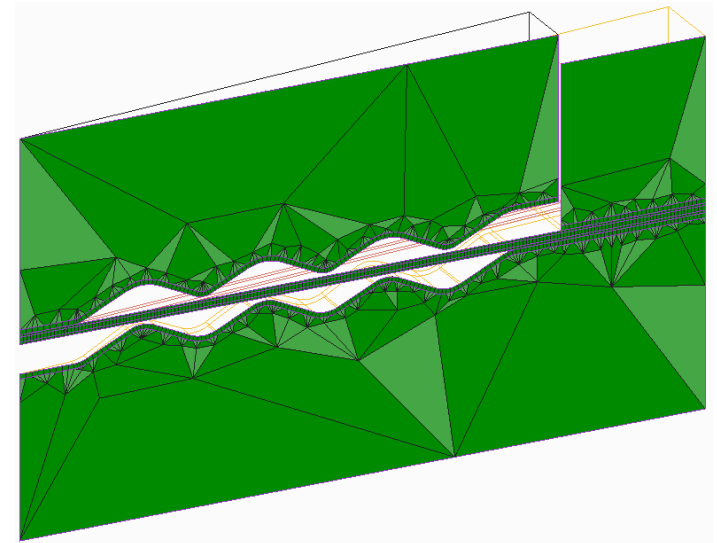
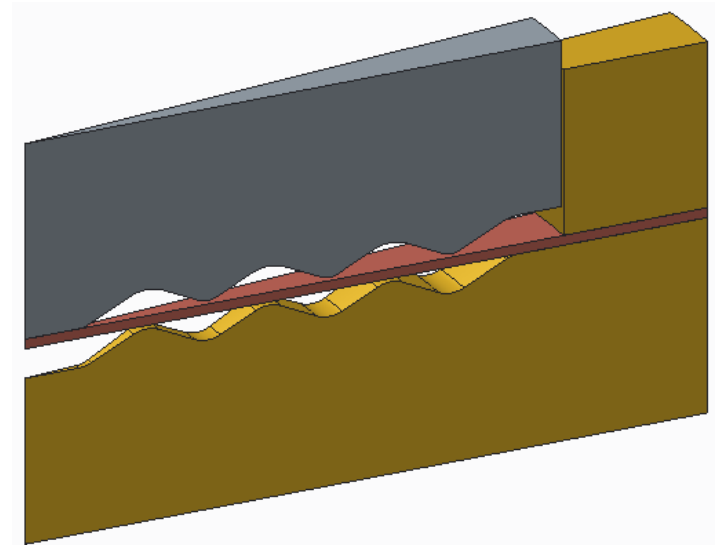

Displacement results animation

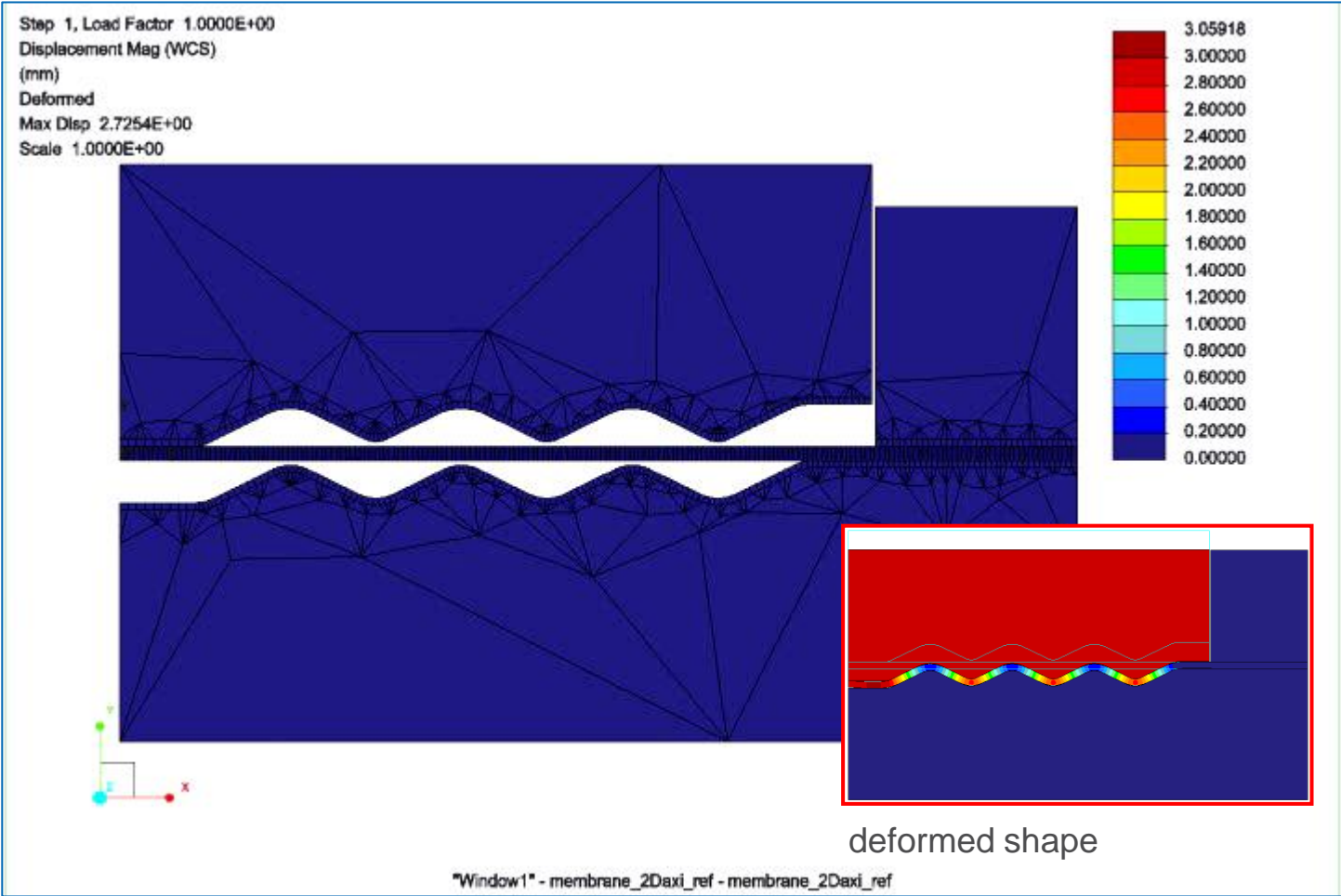

Equivalent plastic strain results animation

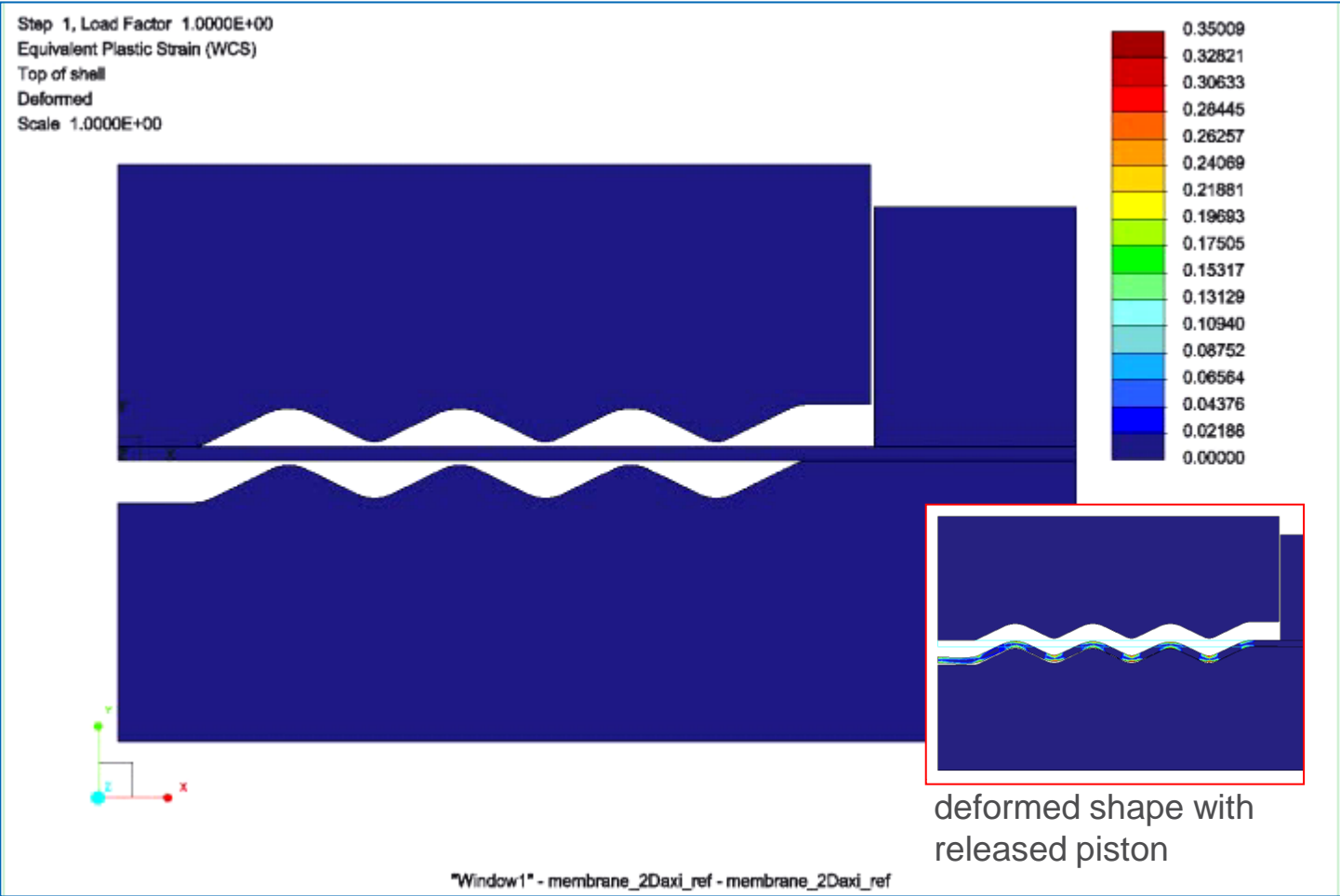

Thanks for your attention!

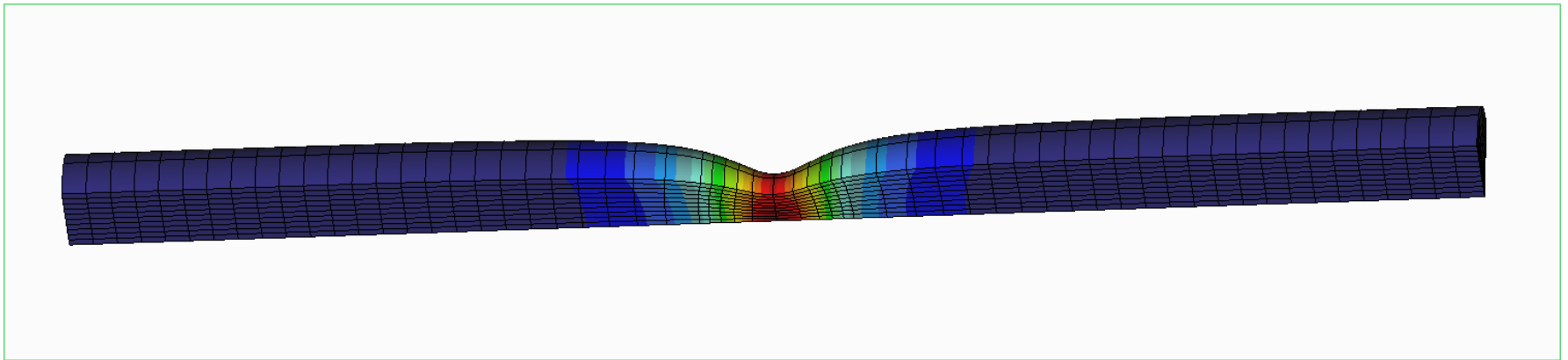

Questions?

Part IV

Appendix

Literature

Technical Dictionary English-German

[1] Wikipedia: Yield (engineering)

[http://en.wikipedia.org/wiki/Yield_\(engineering\)](http://en.wikipedia.org/wiki/Yield_(engineering))

[2] R. Jakel: Analysis of Hyperelastic Materials with MECHANICA

– Theory and Application Examples –

Presentation for the 2nd SAXSIM | Technische Universität Chemnitz

27. April 2010 | Rev. 1.1

[3] W. Domke: Werkstoffkunde und Werkstoffprüfung, 9. Auflage 1981, Verlag W. Giradet, Essen, ISBN 3-7736-1219-2

[4] John Yang, PTC Mechanics R&D: Handwritten Notes

[5] ANSYS Release 11.0 user documentation,
chapter 2.4. Combined Stresses and Strains,

http://www.kxcad.net/ansys/ANSYS/ansyshelp/thy_str4.html

- [6] Gordon R. Johnson, William H. Cook: A constitutive model and data for metals subjected to large strains, high strain rates and high temperatures; Work funded by Contract F08635-81-C-0179 from the U.S. Air Force and a Honeywell Independent Development Program, 1983
- [7] W.F. Hosford, A Generalized Isotropic Yield Criterion, J. Appl. Mech., June 1972, Volume 39, Issue 2, 607
<http://dx.doi.org/10.1115/1.3422732>
- [8] Richard M. Christensen, Prof. Research Emeritus, Aeronautics and Astronautics Dept., Stanford University, <http://www.failurecriteria.com>
- [9] Yanshan Lou, Hoon Huh: Yield loci evaluation of some famous yield criteria with experimental data, KSAE09-J0003, 2009
- [10] R. Jakel: Pro/ENGINEER Mechanical Wildfire 4.0, Workshop Fundamentals II, p. 15 ff, Rev. 2.0.1, 2011 (PTC CER workshop material)

Used vocabulary in this presentation

- dilatation – Dilatation, Ausdehnung
- dislocation: Gitterfehler, Versetzung
- elastic – perfectly plastic material law: ideal elastisch – ideal plastisches Materialgesetz
- elongation without necking: Gleichmaßdehnung
- elongation with necking: Einschnürdehnung
- finite strain plasticity: Theorie der Plastizität großer Deformationen
- gray cast iron: Grauguss
- hardened steel: gehärteter Stahl
- isotropic hardening: Isotrope Verfestigung
- kinematic hardening: Kinematische Verfestigung
- tempered steel: vergüteter Stahl
- proof stress: Dehngrenze, Ersatzstreckgrenze
- soft steel: weicher Stahl
- small strain plasticity: Theorie der Plastizität kleiner Deformationen
- stretch: Streckung ($\lambda = l_1/l_0 = 1+\varepsilon$)
- yield limit: Fließgrenze