



Solid Tooling for Pro/NC

Solid Tooling in Pro/NC

Agenda

- Key Issues
- Creating Solid Tools
- Using and Maintaining Solid Tools
- Next Steps
- Questions

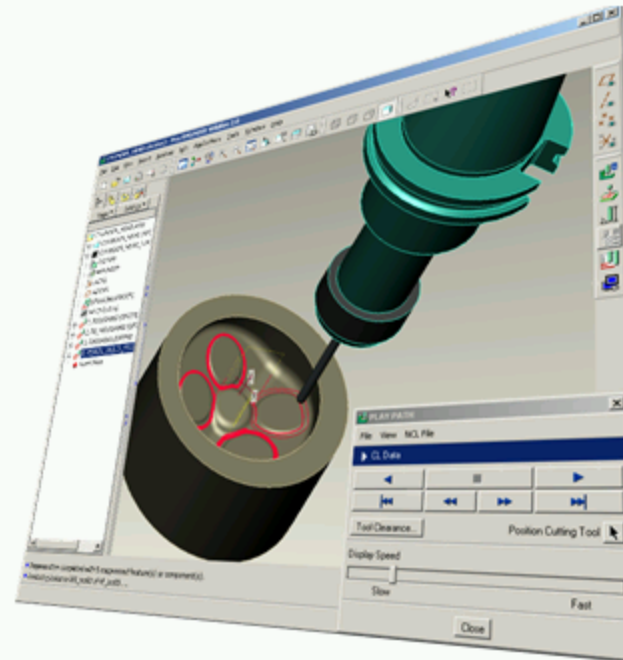

Solid Tooling in Pro/NC

Solid Tooling in Pro/NC – Key Issues

Why?

- Machining Simulation
- Gouge Checking
- Complex Tooling
- Eye Candy – Impress the customer
- New in WF2 – Shaded solid tool display during playback

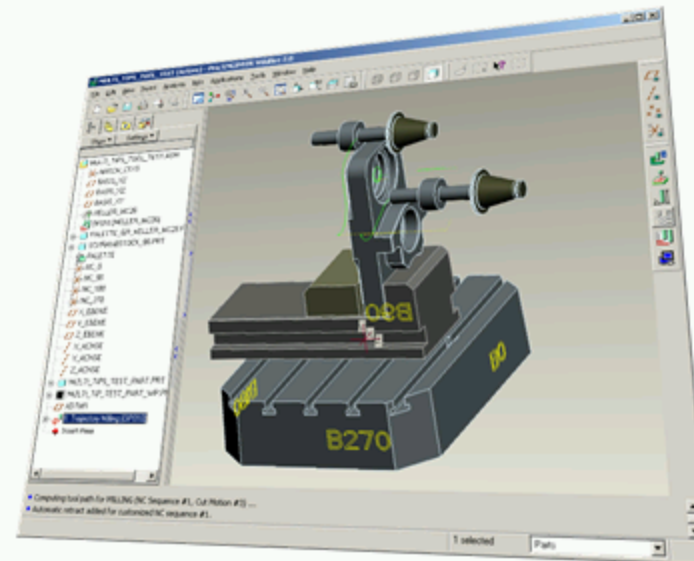

Solid Tooling in Pro/NC – Key Issues

Solid Tooling in Pro/NC – Creating Solid Tools

The Basics

- ◉ Pro/E Model of Tool
- ◉ Pro/E Model of Holder (optional)
- ◉ Appropriate Parameters:
 - Cutter Diameter
 - Length
 - ...
- ◉ Coordinate System for Drive Point

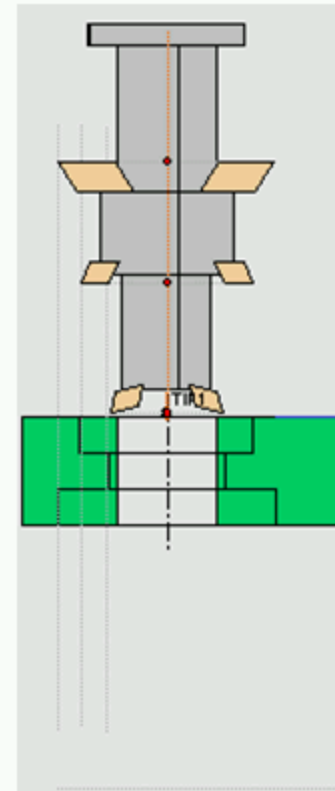

Solid Tooling in Pro/NC – Creating Solid Tools

Solid Tooling in Pro/NC – Creating Solid Tools

The Pro/E Model of Tool

- ⦿ As complex or as simple as desired.
- ⦿ Flutes, colors, etc.
- ⦿ Family Tables are usually a good tool for construction and retrieval, but optional.
- ⦿ Name them anything that makes sense to you.



Solid Tooling in Pro/NC – Creating Solid Tools

Solid Tooling in Pro/NC – Creating Solid Tools

The Pro/E Model of Tool - continued

- Need to know what parameters will be needed
- Easiest way: build a parametric tool and then *Show Tool Info*:

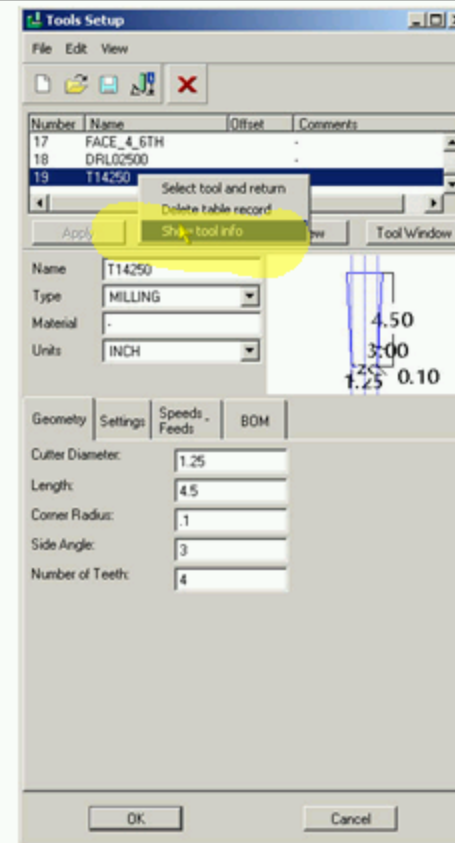
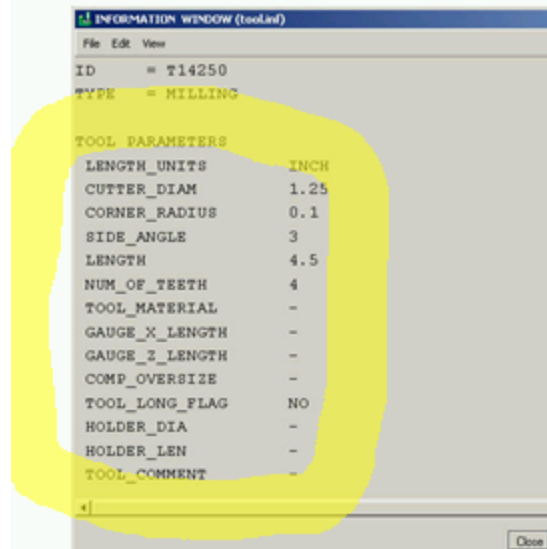

Solid Tooling in Pro/NC – Creating Solid Tools

Solid Tooling in Pro/NC – Creating Solid Tools

The Pro/E Model of Tool - continued

- ⦿ These parameters need to be called out in the tool part model in order for them to be transferred to Pro/NC
- ⦿ Can be done by editing the feature dimensions:
 - Changing $d12$ to be *length*; or
- ⦿ Adding part level parameters:
 - *Length = 4.000*

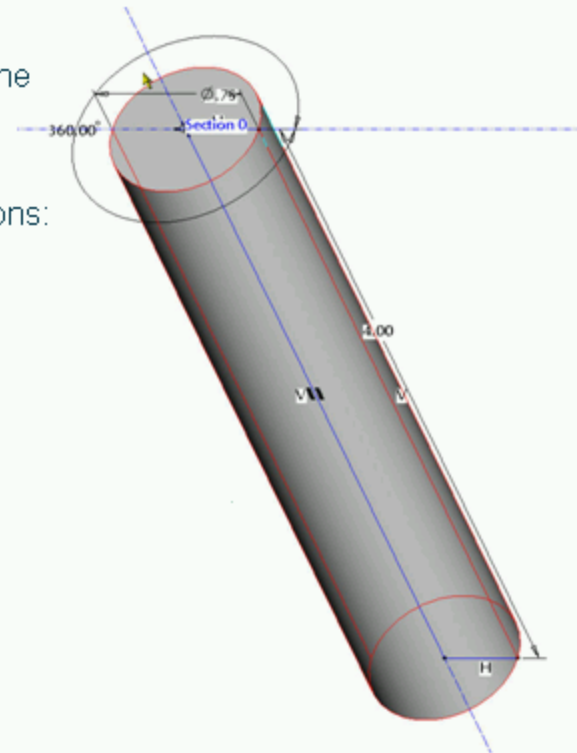

Solid Tooling in Pro/NC – Creating Solid Tools

Solid Tooling in Pro/NC – Creating Solid Tools

The Pro/E Model of Tool - continued

- ◉ Editing the feature dimensions:
 - Highlight Feature
 - *Edit*
 - Click on dimension tag
 - *Properties*
 - Dimension Text tab
 - *Name*
 - Change from default (d5) to appropriate parameter (cutter_diam)

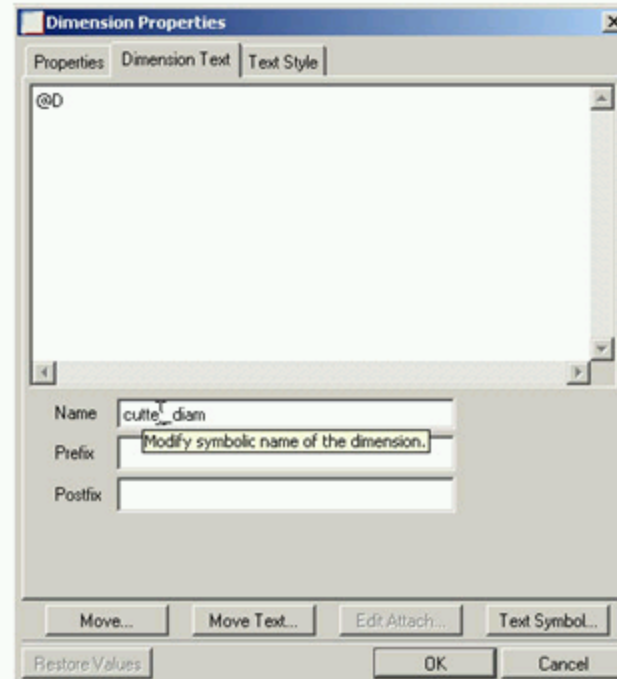

Solid Tooling in Pro/NC – Creating Solid Tools

Solid Tooling in Pro/NC – Creating Solid Tools

The Pro/E Model of Tool - continued

- ◉ Adding part level parameters:
 - *Tools/Parameters*
 - Add 
 - *Name, Real Number, Value*
 - LENGTH, Real Number, 4.5000

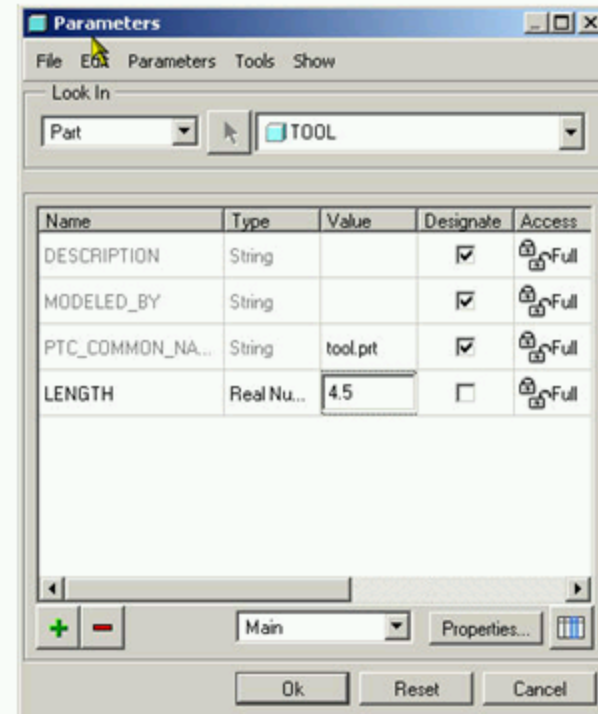
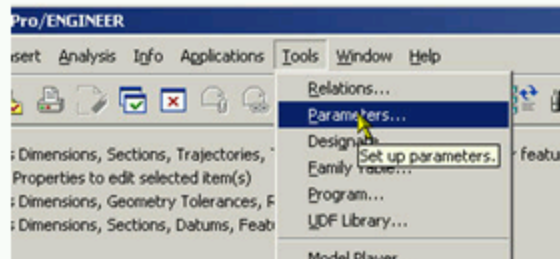

Solid Tooling in Pro/NC – Creating Solid Tools

Solid Tooling in Pro/NC – Creating Solid Tools

The Pro/E Model of Tool - continued

- Add a Coordinate System feature at the appropriate tool tip location
- Z axis positive along the tool axis
- Rename the feature "TIP"

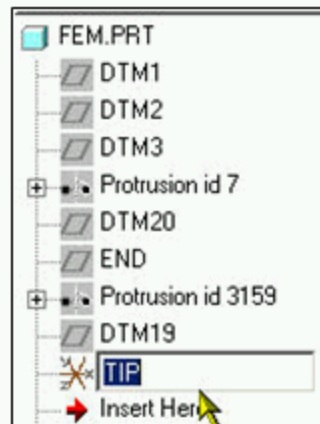

Solid Tooling in Pro/NC – Creating Solid Tools

Solid Tooling in Pro/NC – Creating Solid Tools

The Pro/E Model of Holder

- ◉ Optional
- ◉ Construct part model of holder
- ◉ Assemble components into assembly
- ◉ This assembly is now the tool model used in Pro/NC
- ◉ Family Table
- ◉ Add parameter VERICUT_TYPE set to HOLDER.

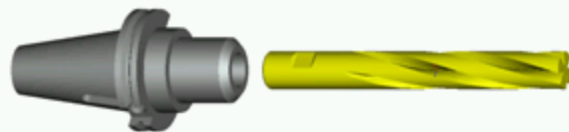

Solid Tooling in Pro/NC – Creating Solid Tools

Solid Tooling in Pro/NC – Creating Solid Tools

The Pro/E Model of Holder - Continued

⦿ Important:

- If an assembly is used as a tool model, the system will search the assembly first, and then all the component parts in the same order as they were assembled (that is, the first component will be searched first), for the tool parameters and origin data.
- Once a parameter is set, all values for the same parameter found later will be ignored. In other words, the top-level assembly parameters take precedence over component parameters, and after that the precedence is determined by the order of assembly.
- If, after all components are searched, some of the tool parameters are missing, an error message will appear and you will be asked to select another tool.



Solid Tooling in Pro/NC – Creating Solid Tools

Solid Tooling in Pro/NC – Using Solid Tools

Storage:

- Create solid tool library with subdirectories as needed.
- Config.pro option for pointing, same as parameter tools – *pro_mf_tprm.dir*
- Set datums to hidden

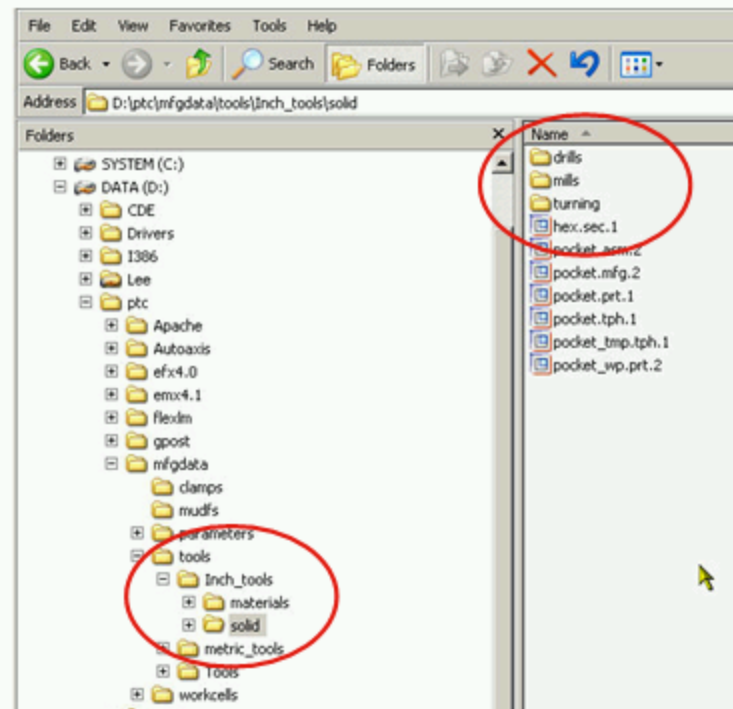
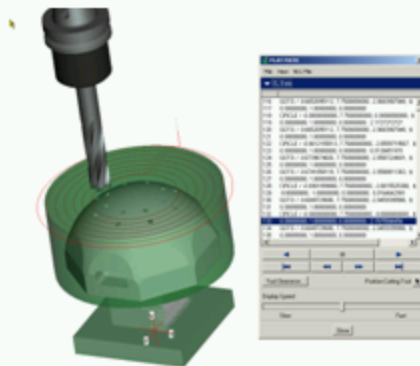

Solid Tooling in Pro/NC – Using Solid Tools

Solid Tooling in Pro/NC – Using Solid Tools

Use solid tools:

- ⦿ Open tool setup menu.
- ⦿ Important: when bringing in a new cutter, make sure the active tool type is correct (milling, drill, etc.) You might need to make a new dummy tool first. This problem is eliminated if you add to the tool part a parameter TOOL_TYPE.
- ⦿ *Select File/Open Tool Library*
- ⦿ *By Reference*: Tool is associative to original tool part/assy. If the tool model changes, the tool definition changes.
- ⦿ *By Copy*: Tool information is input but changeable.



Solid Tooling in Pro/NC – Using Solid Tools

Solid Tooling in Pro/NC – Using Solid Tools

Use solid tools: continued

- Create tool path as normal.
- Play toolpath. Screen play shows tool in shaded mode.
- Note: during Customize, tool shown is simply parameter tool. Complete toolpath, select Screen Play and solid tool is shown.

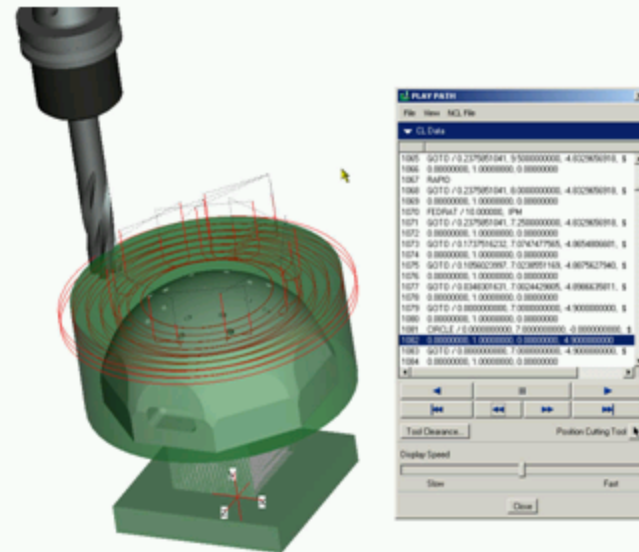

Solid Tooling in Pro/NC – Using Solid Tools

Solid Tooling in Pro/NC – Using Solid Tools

Use solid tools: continued

- Gouge Avoidance.
- During toolpath calculation, only tool parameters are used, not actual tool definition.
- Tool holder is degouged only according to sequence parameters HOLDER_LENGTH and HOLDER_DIAMETER, not actual holder definition.
- Position tool during Screen Play to observe any problems.

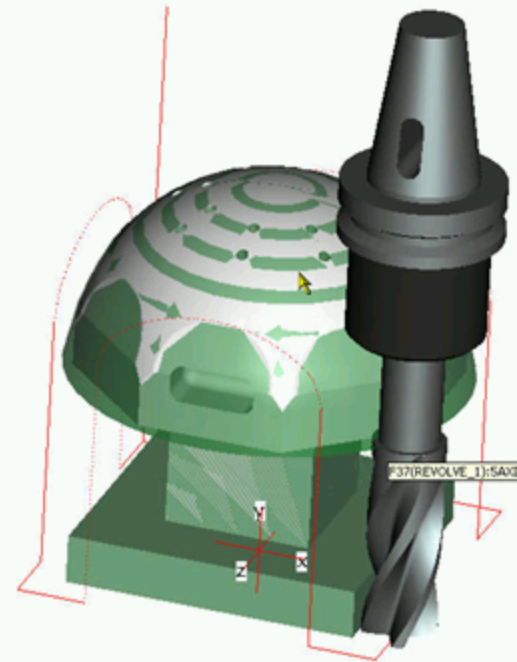

Solid Tooling in Pro/NC – Using Solid Tools



Solid Tooling in Pro/NC – Using Solid Tools

Use solid tools: continued

- Vericut uses solid tools.
- For milling, uses rotational envelope.
- For turning, uses tool profile.

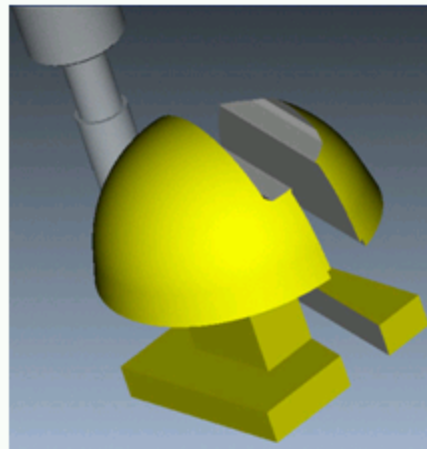
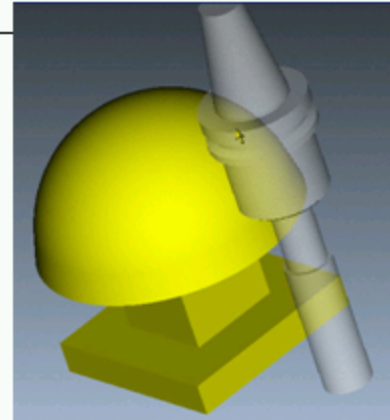

Solid Tooling in Pro/NC – Using Solid Tools

A Sharing Slide

Demonstration

Solid Tooling in Pro/NC – Using Solid Tools

Use solid tools: continued

- Turning tools work the same.

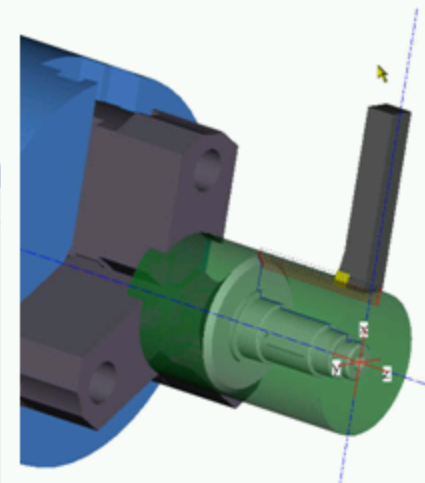
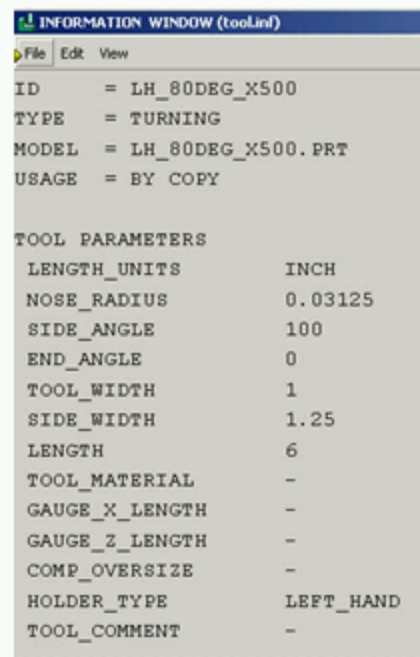
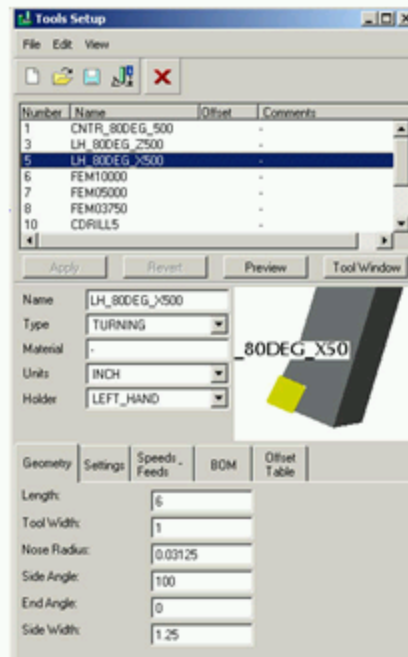

Solid Tooling in Pro/NC – Using Solid Tools



Solid Tooling in Pro/NC – Using Solid Tools

Where can I find existing models?

- Ptc.com.
- Support/Order and License Support



Solid Tooling in Pro/NC – Using Solid Tools

Solid Tooling in Pro/NC – Using Solid Tools

Where can I find existing models?

- ⦿ Order or Download software updates
- ⦿ Choose Pro/ENGINEER

Update existing contacts & addresses, update language platform information.

Order support

[View software update availability](#)
Review all software updates available online.

[Order or Download software updates](#)
Request current version of your PTC software.

[Track shipments](#)
Track your maintenance and software shipments.

Order or Download Software Updates

PTC Technical Support is pleased to provide an electronic to provide an easier avenue for requesting software updates. In a web browser, software updates can be ordered on CD or electronically downloaded without calling Technical Support.

[Order or Download Software Updates](#)

Application Notes

- If multiple PTC products are used simultaneously, [product compatibility](#).

Select Products

Product Name
PRO/ENGINEER

Solid Tooling in Pro/NC – Using Solid Tools

Solid Tooling in Pro/NC – Using Solid Tools

Where can I find existing models?

- Scroll down or search for "tooling"
- Wildfire Library – tooling.zip

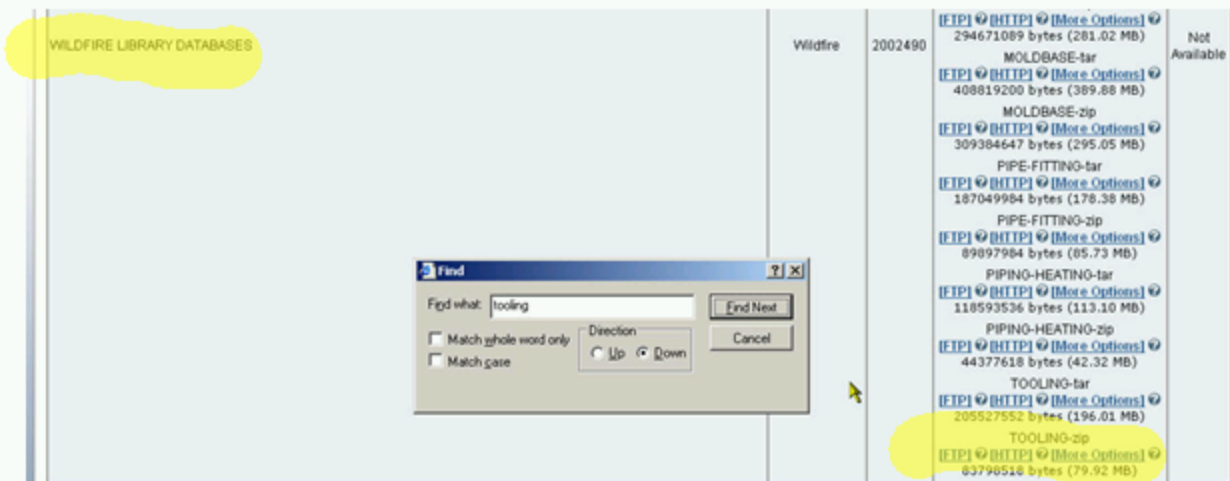

Solid Tooling in Pro/NC – Using Solid Tools

Solid Tooling in Pro/NC – Using Solid Tools

Where can I find existing models?

- Endmills, drills, turning tools
- Also, fixtures, plates, tombstones, ...

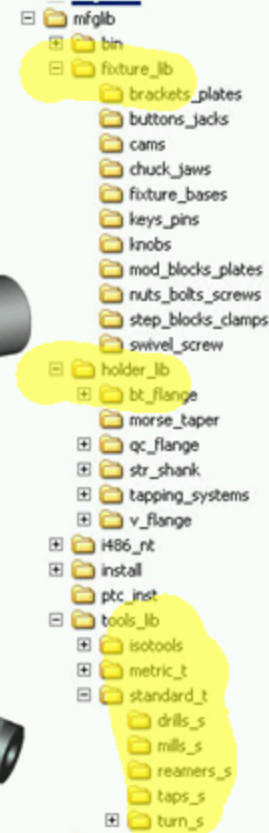
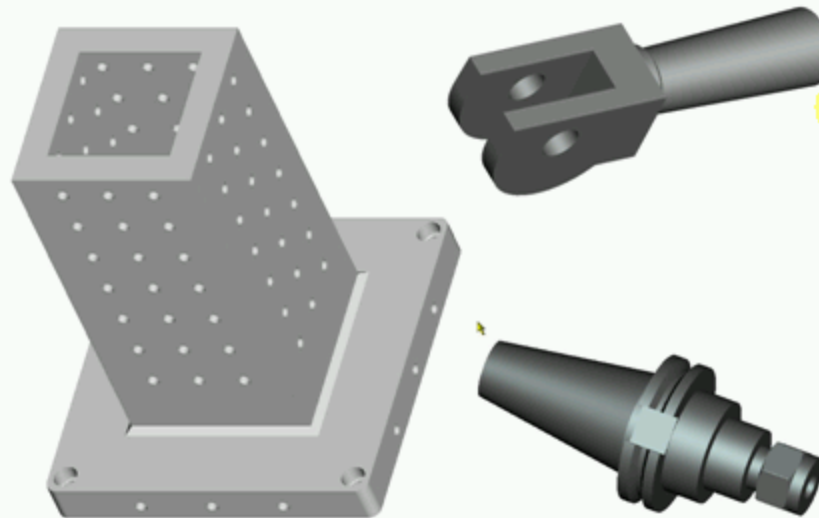

Solid Tooling in Pro/NC – Using Solid Tools

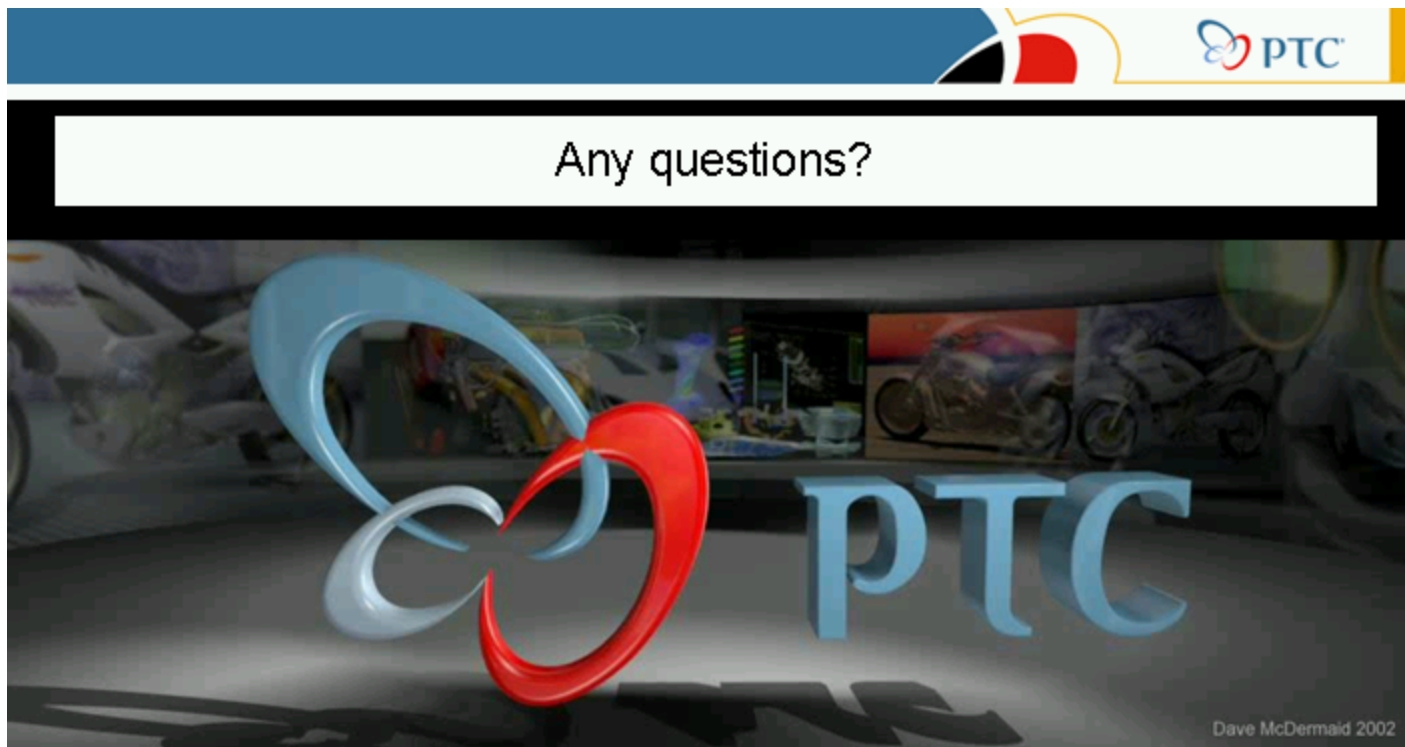

Any questions?

Dave McDermid 2002

Production Industrial Design Routed Systems Simulation 3D Drawings

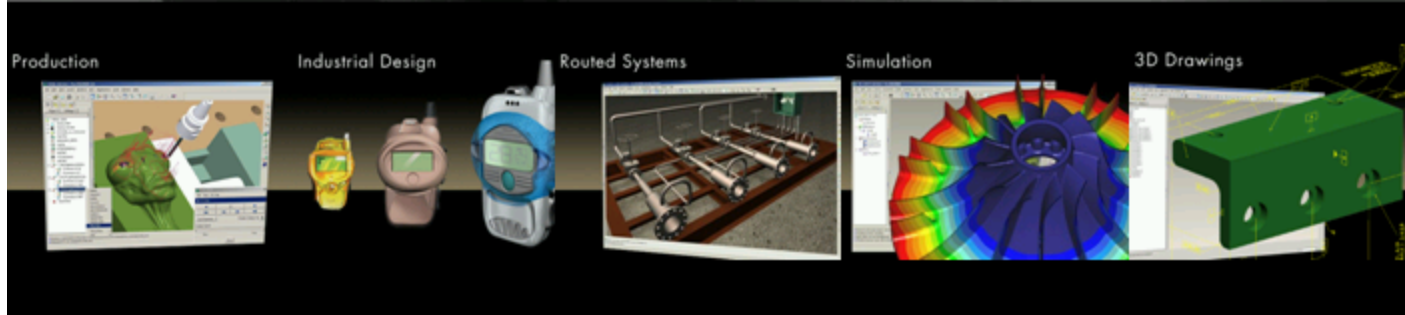

Any questions?